

Application

The globe control valve BR11 is used in automated, industrial installations to control the flow of gases and liquids. Design and production meets the requirements of Quality Management System ISO 9001. The wide range of materials and the various configuration options make this valve very popular in the chemical and petrochemical industry.

Features

- » Nominal Diameters from DN15 up to DN250
- » Nominal Pressure from PN10 up to CL300
- » Face-to-Face length as per DIN EN 60534-3-1 or ANSI/ISA 75.08
- » Temperature range -196°C up to +400°C
- » Leakage Class IV and VI according to DIN EN 60534-4
- » Characteristic: Linear (L); Equal-percentage (P); ON/OFF [quick-opening] (S)
- » Rangeability 50:1
- » Design with Flange ends, TA-Luft, Bellows seal bonnet possible
- » Optional using of balanced plug (>DN40) allows the reduction of actuation forces
- » Better control characteristic trough lager stroke
- » Higher maximum KVs-values
- » Exact spindle guid, in diameters DN15 - DN100 by using of long guide, including hardened guiding sleeve
- » Stem guided in diameters DN125 - DN250
- » Design as per Pressure Equipment Directive 2014/68/EU
- » Conformity CE and EAC
- » Optional certification/confirmation according to ATEX 2014/34/EU, GOST-R (TR), SIL2 (IEC 61508) and AD2000 Merkblatt



Design and technical Specification

Diameters: DN15; 20; 25; 32; 40; 50; 65; 80; 100; 125; 150; 200; 250

Pressure: PN10; 16; 25; 40 as per DIN EN 1092-1:2013 and DIN EN 1092-2:1999
ANSI CL150; 300 and DIN EN 1759-1:2005

Flanges as per DIN EN 1759-1:2005 can be assembled with flanges execution per standards ANSI / ASME B1 6.5 and MSS SP44. They correspond to the standard DIN EN 7005-1:2002 following pressure ranges: CL150 \triangleq PN20 and CL300 \triangleq PN50

Table 1 Flange Versions

Material	Nominal Pressure	Raised Face	Flange Facing		
			Groove	Recess	Ring-Joint
Identification					
Cast Iron	PN10; 16	B ²⁾	-	-	-
Ductile Iron	PN10; 16; 25; 40		-	-	-
Carbon Steel Stainless Steel	PN10; 16; 25; 40		D	F	-
	CL150		-	-	J (RTJ)
CL300	DL (D1 ¹⁾)	F (F1)			
¹⁾ only for CL300; ²⁾ B1 - (Ra = 12,5 mm, concentric surface structure "C"), B2 - (Ra as agreed with the customer); (-) - as per ASME B1 6.5					

Table 2 Packing and Bonnet Versions

Packing	PN / CL	Temperature [°C]		
		Standard	Valve Bonnet Extended	Bellows Seal
PTFE V-Ring	PN10...CL300	-46*...+200	-196*...-46* +200...+300	-100*...+200
PTFE+Graphit				
PTFE V-Ring / TA-Luft		+200...+300	+300...+400	+200...+400
Graphit				
Graphit / TA-Luft				
* The use of a cryogenic bonnet is necessary from temperature as of -29°C!				

Table 3 Temperature Range depending on Execution

Execution	Operating Temperature [°C]		Max. Operating Pressure [bar]
	Min.	Max.	
Balanced Plug	- 50	+250	40
Soft seated (PTFE inlay)	-100	+260	35
Bellows Seal Bonnet	-100	+400	35

Body (1); Bonnet (2); Valve Plug (3); Valve Seat (4); Valve Stem (5); Drain Plug (6); Body Gasket (7)

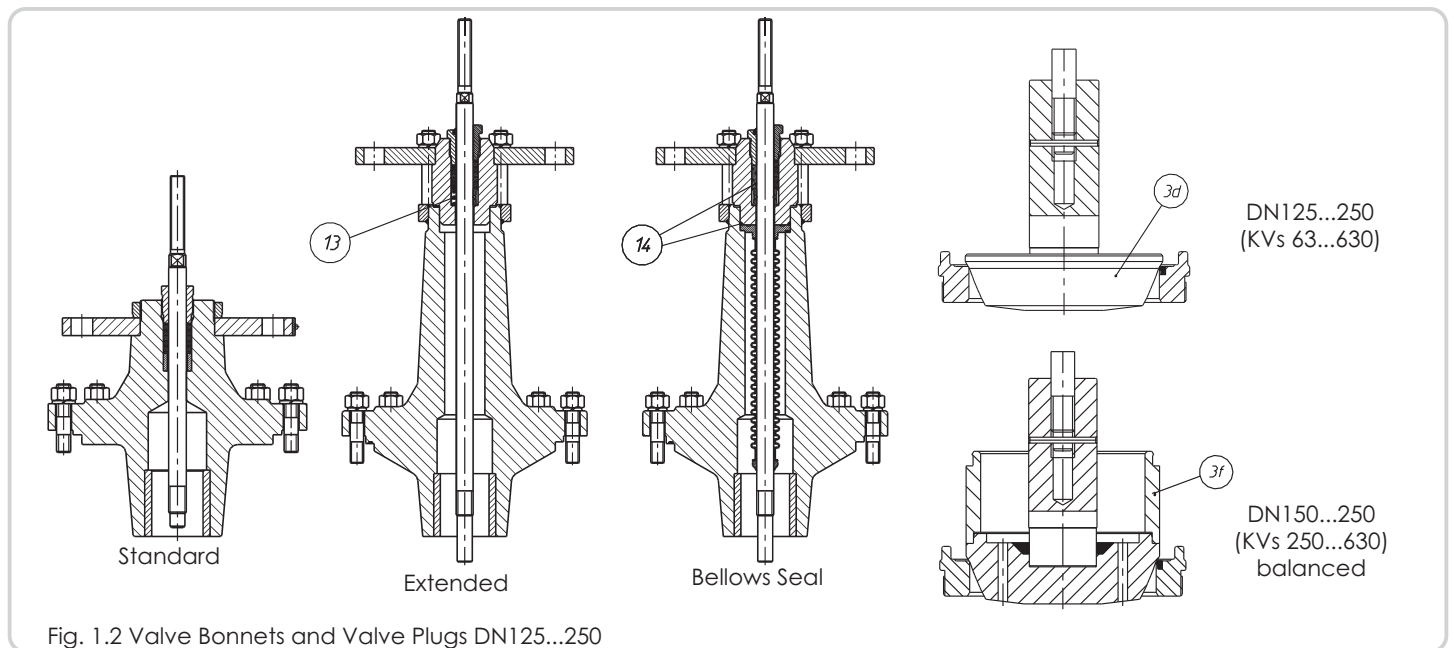
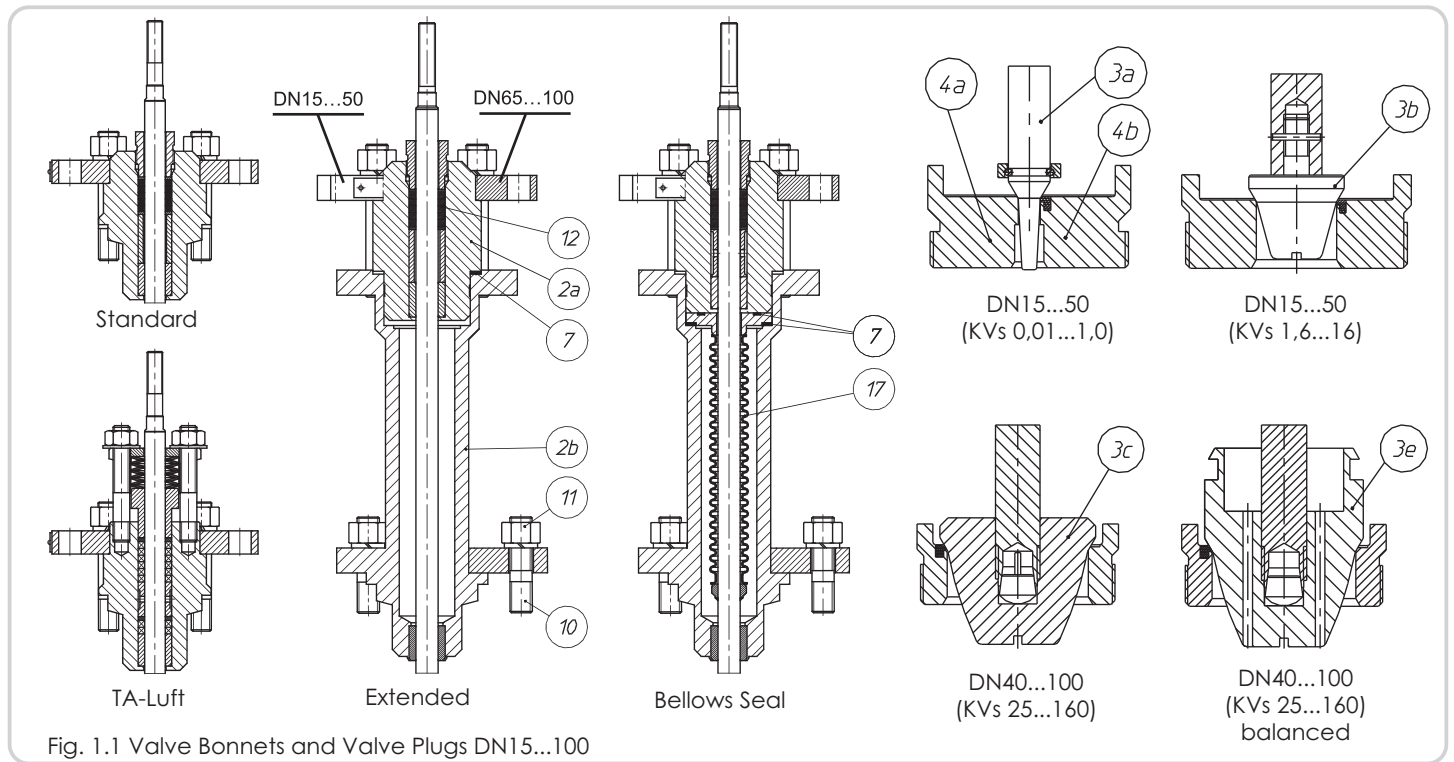

NOTE:
PRE-VENT control valves are supplied with an adjustable stuffing box as standard. Using a spring-loaded packing box the max. operating temperature is +300°C.

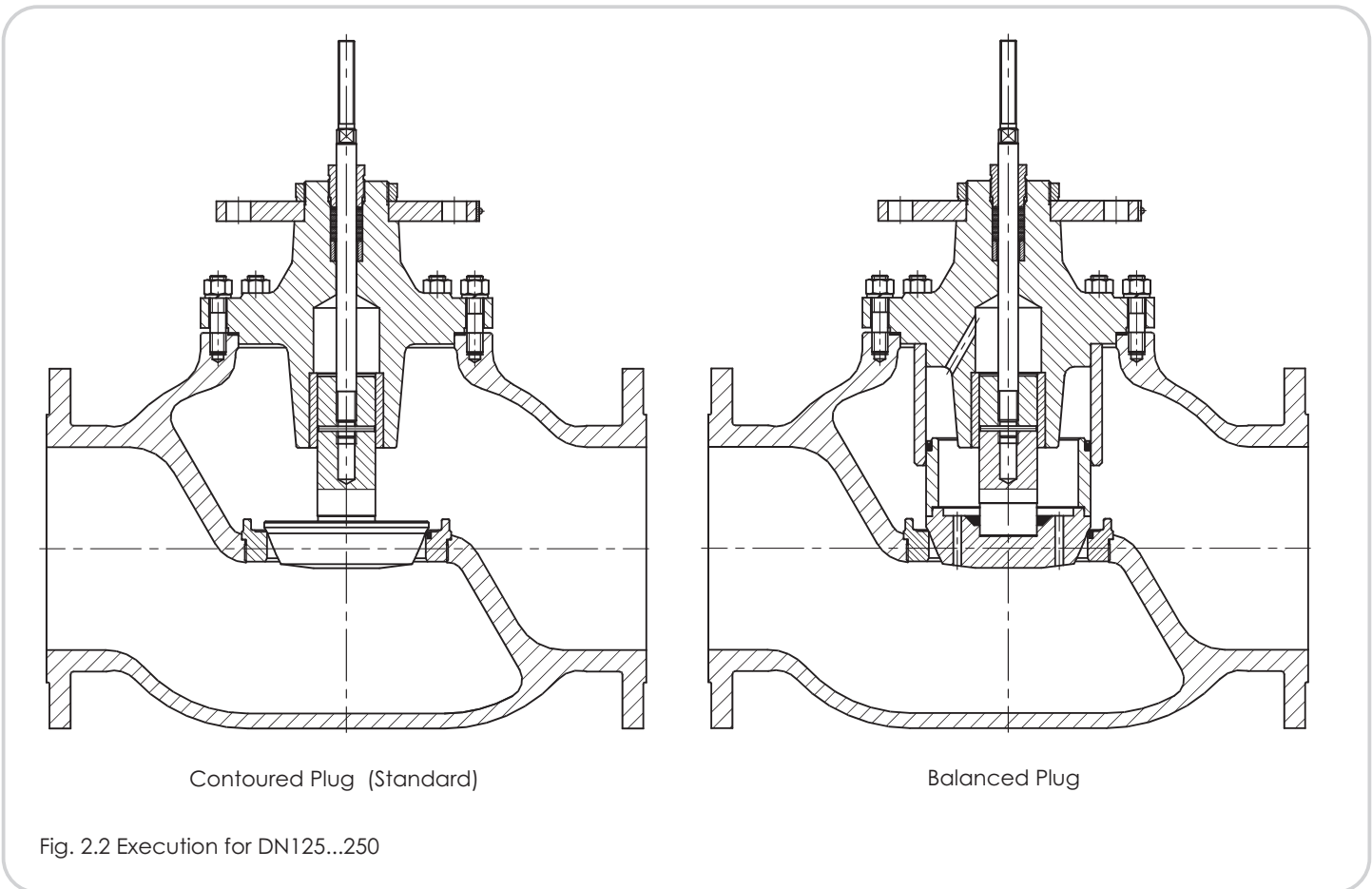
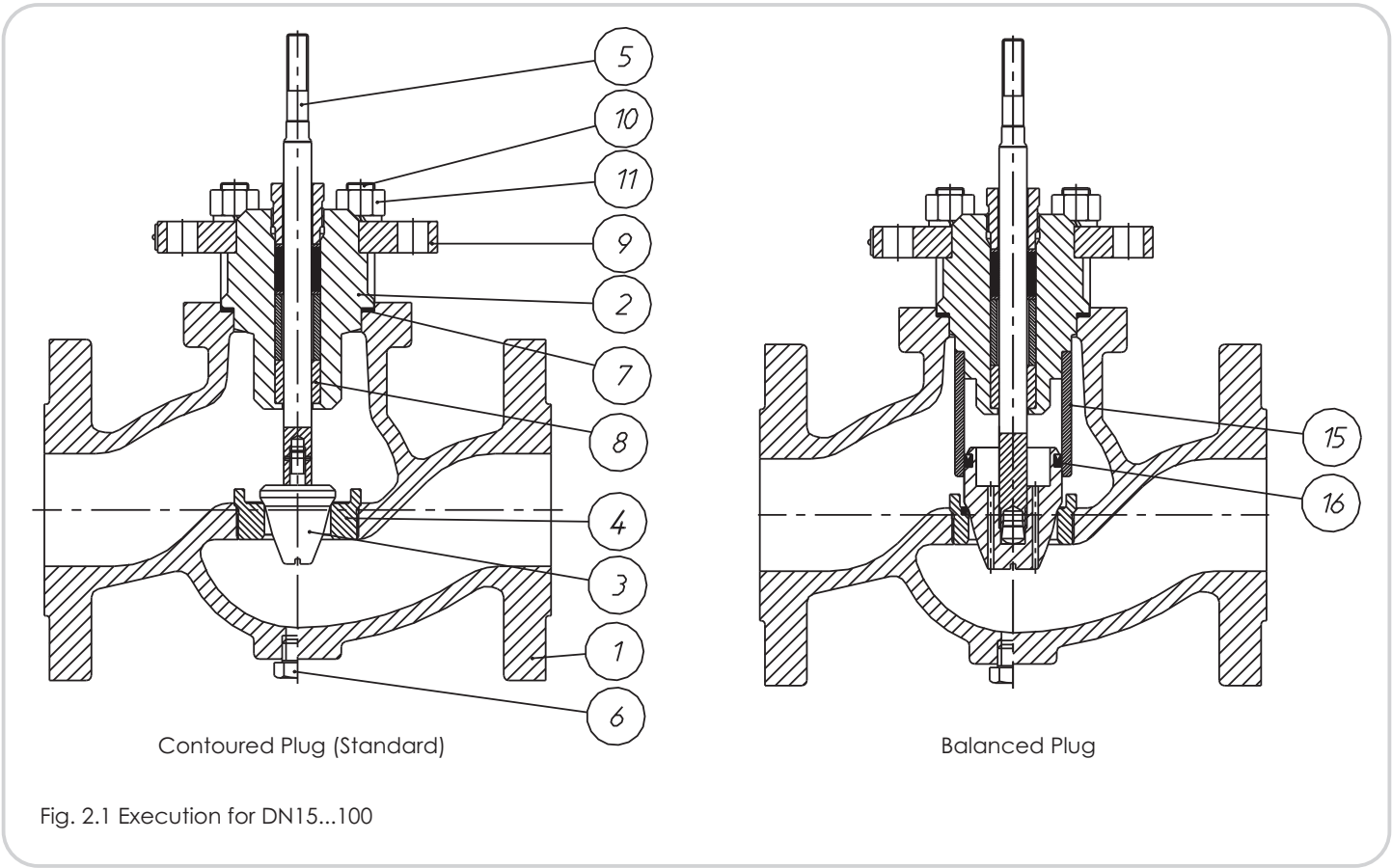

Table 4 Components and Materials

No.	Component		Material					
1	Body		EN-GJL250 (EN-JL1040)	EN-GJS400-18LT (EN-JS1025)	GP240GH (1.0619) WCB	G20Mn5 (1.6220)	G17CrMo9-10 (1.7379) WC9	GX5CrNiMo19-11-2 (1.4408) CF8M
2	Bonnet	DN15...100	S 355 J2G3 (1.0570)				13CrMo4-4 (1.7335)	X6CrNiMoTi17-12-2 (1.4571)
		DN125...250	EN-GJL250 (EN-JL1040)	EN-GJS400-18LT (EN-JS1025)	GP240GH (1.0619) WCB	G20Mn5 (1.6220)	G17CrMo9-10 (1.7379) WC9	GX5CrNiMo19-11-2 (1.4408) CF8M
3	Plug		X6CrNiMoTi17-12-2 (1.4571) X6CrNiMoTi17-12-2 (1.4571) + Stellite + Chrom(III)-nitride X17CrNi16-2 (1.4057) + heat treatment					
4	Seat		X6CrNiMoTi17-12-2 (1.4571) X6CrNiMoTi17-12-2 (1.4571) + Stellite X6CrNiMoTi17-12-2 (1.4571) + PTFE X17CrNi16-2 (1.4057) + heat treatment					
5	Stem		X6CrNiMoTi17-12-2 (1.4571) X6CrNiMoTi17-12-2 (1.4571) + Stellite + Chrom(III)-nitride X17CrNi16-2 (1.4057) + heat treatment					
6	Drain Plug		S 355J2G3 (1.0570)			X6CrNiMoTi17-12-2 (1.4571)		
7	Body Gasket		X6CrNiMoTi17-12-2 (1.4571), NOVATEC PREMIUM SIGRAFLEX HOCHDRUCK, MWK-50 SPETOMET					
8	Guiding Sleeve		X6CrNiMoTi17-12-2 (1.4571)					
9	Compression plate		C45 (1.0503), X30Cr13 (1.4028), X6CrNiMoTi17-12-2 (1.4571)					
10	Bolt		8.8			A4 - 70		
11	Nut		8			A4 - 70		
12	Packing		PTFE+Graphite, PTFE-V, Graphite					
13	Spring		12R10 (SANDVIK)					
14	O-Ring		FKM					
15	Guiding Sleeve		X6CrNiMoTi17-12-2 (1.4571) X6CrNiMoTi17-12-2 (1.4571) + Stellite + Chrom(III)-nitrid X17CrNi16-2 (1.4057) + heat treatment					
16	Sael Ring		PTFE + X6CrNiMoTi17-12-2 (1.4571), TURCON + X6CrNiMoTi17-12-2 (1.4571)					
17	Bellows Seal		X6CrNiMoTi17-12-2 (1.4571)					
•	Rec. Spare Parts							

Material	Standard
EN-GJL250 (EN-JL1040)	DIN EN 1561
EN-GJS400-18 LT (EN-JS 1025)	DIN EN 1563
GP240GH (1.0619)	DIN EN 10213-2
WCB	ASTM A 216
G20Mn5 (1.6220)	EIN EN 10213-3
G17CrMo9-10 (1.7379)	DIN EN 10213-2
WC9	ASTM A217
13CrMo4-4 (1.7335)	DIN EN 10028
GX5CrNiMo19-11-2 (1.4408)	DIN EN 10213-4
CF8M	ASTM A351
S355J2G3 (1.0570)	DIN EN 10025
X6CrNiMoTi17-12-2 (1.4571)	DIN EN 10088
X17CrNi16-2 (1.4057)	DIN EN 10088
C45 (1.0503)	DIN EN 10083-1
X30Cr13 (1.4028)	DIN EN 10088

NOTE:

- » Padding of Surface with Stellite: ~ 40HRC
- » Chrom(III)-nitride Coating (~ 0,1 mm): ~ 950HV
- » Heat treatment (quenched & tempered): Plug ~ 45HRC; Seat ~ 35HRC; Stem ~ 35HRC; Guiding Sleeve~ 45HRC

For acid Fluids it is recommend to use trim materials made from 1.4404 or 316L. For H2S-applications it is possible to provide NACE MR-0175. NACE is only possible with ASME/ASTM Materials.

Table 5a...5f Allowable Operating Pressure (DIN)

Table 5a		Material: EN-GJL250 (EN-JL1040) as per DIN EN 1561								
PN	Standard	Temperature [°C]								
		-10...+50	100	150	200	250	300	350	400	450
Max. Operating Pressure [bar]										
PN10	DIN EN 1092-2	10	10	9	8	7	6	-	-	-
PN16		16	16	14,4	12,8	11,2	9,6	-	-	-

Table 5b		Material: EN-GJS400-18 LT (EN-JS1025) as per DIN EN 1563								
PN	Standard	Temperature [°C]								
		-10...+50	100	150	200	250	300	350	400	450
Max. Operating Pressure [bar]										
PN10	DIN EN 1092-2	10	10	9,7	9,2	8,7	8	7	-	-
PN16		16	16	15,5	14,7	13,9	12,8	11,2	-	-
PN25		25	25	24,3	23	21,8	20	17	-	-
PN40		40	40	38,8	36,8	34,8	32	28	-	-

Table 5c		Material: GP240GH (1.0619) as per DIN EN 10213-2								
PN / CL	Standard	Temperature [°C]								
		-10...+50	100	150	200	250	300	350	400	450
Max. Operating Pressure [bar]										
PN10	DIN EN 1092-1	10	9,2	8,8	8,3	7,6	6,9	6,4	5,9	-
PN16		16	14,8	14	13,3	12,1	11	10,2	9,5	-
CL150	DIN EN 1759-1	17,3	15,4	14,6	13,8	12,1	10,2	8,4	6,5	-
PN25	DIN EN 1092-1	25	23,2	22	20,8	19	17,2	16	14,8	-
PN40		40	37,1	35,2	33,3	30,4	27,6	25,7	23,8	-
CL300	DIN EN 1759-1	45,3	40,1	38,1	36	32,9	29,8	27,8	25,7	-

Table 5d		Material: G20Mn5 (1.6220) as per DIN EN 10213-3								
PN	Standard	Temperature [°C]								
		-40	100	150	200	250	300	350	400	450
Max. Operating Pressure [bar]										
PN10	-	6	6	3,8	3,6	3,48	3,4	-	-	-
PN16		16	16	10,1	9,6	9,28	9,07	-	-	-
PN25		25	25	15,8	15	14,5	14,2	-	-	-
PN40		40	28	28	27	26	25	-	-	-

Table 5e		Material: G17CrMo9-10 (1.7379) as per DIN EN 10213-2								
PN / CL	Standard	Temperature [°C]								
		-10...+50	100	150	200	250	300	350	400	450
Max. Operating Pressure [bar]										
PN10	-	10	10	10	10	10	10	9,7	9,2	-
PN16		16	16	16	16	16	16	15,6	14,8	-
CL150	DIN EN 1759-1	19,5	17,7	15,8	14	12,1	10,2	8,4	6,5	-
PN25	DIN EN 1092-1	25	25	25	25	25	25	24,4	23,2	-
PN40		40	40	40	40	40	40	39	37,1	-
CL300	DIN EN 1759-1	51,7	51,5	50,2	48,3	46,3	42,8	40,2	36,6	-

Table 5f		Material: GX5CrNiMo19-11-2 (1.4408) as per DIN EN 10213-4								
PN / CL	Standard	Temperature [°C]								
		-10...+50	100	150	200	250	300	350	400	450
Max. Operating Pressure [bar]										
PN10	DIN EN 1092-1	10	10	9	8,4	7,9	7,4	7,1	6,8	-
PN16		16	16	14,5	13,4	12,7	11,8	11,4	10,9	-
CL150	DIN EN 1759-1	17,9	16,3	14,9	13,5	12,1	10,2	8,4	6,5	-
PN25	DIN EN 1092-1	25	25	22,7	21	19,8	18,5	17,8	17,1	-
PN40		40	40	36,3	33,7	31,8	29,7	28,5	27,4	-
CL300	DIN EN 1759-1	46,7	42,5	38,9	35,3	32,9	30,5	28,8	27,6	-

Table 5g...5i Allowable Operating Pressure (ASTM)

Table 5g		Material: WCB as per ASTM A216								
PN / CL	Standard	Temperature [°C]								
		-10...+50	100	150	200	250	300	350	400	450
Max. Operating Pressure [bar]										
PN10	DIN EN 1092-1	10	10	9,7	9,4	9	8,3	7,9	6,7	-
PN16		16	16	15,6	15,1	14,4	13,4	12,8	10,8	-
CL150	DIN EN 1759-1	19,3	17,7	15,8	14	12,1	10,2	8,4	6,5	-
PN25	DIN EN 1092-1	25	25	24,4	23,7	22,5	20,9	20	16,9	-
PN40		40	40	39,1	37,9	36	33,5	31,9	27	-
CL300	DIN EN 1759-1	50	46,4	45,1	43,9	41,8	38,9	36,9	34,6	-

Table 5h		Material: WC9 as per ASTM A217								
PN / CL	Standard	Temperature [°C]								
		-10...+50	100	150	200	250	300	350	400	450
Max. Operating Pressure [bar]										
PN10	DIN EN 1092-1	10	10	10	10	10	10	10	9,9	-
PN16		16	16	16	16	16	16	16	16	15,9
CL150	DIN EN 1759-1	19,5	17,7	15,8	14	12,1	10,2	8,4	6,5	-
PN25	DIN EN 1092-1	25	25	25	25	25	25	25	24,8	-
PN40		40	40	40	40	40	40	40	40	39,7
CL300	DIN EN 1759-1	51,7	51,5	50,3	48,7	46,3	42,9	40,4	36,5	-

Table 5i		Material: CF8M as per ASTM A351								
PN / CL	Standard	Temperature [°C]								
		-10...+50	100	150	200	250	300	350	400	450
Max. Operating Pressure [bar]										
PN10	DIN EN 1092-1	8,9	7,8	7,1	6,6	6,1	5,8	5,6	5,4	-
PN16		14,3	12,5	11,4	10,6	9,8	9,3	9	8,7	-
CL150	DIN EN 1759-1	18,4	16	14,8	13,6	12	10,2	8,4	6,5	-
PN25	DIN EN 1092-1	22,3	19,5	17,8	16,5	15,5	14,6	14,1	13,6	-
PN40		35,6	31,3	28,5	26,4	24,7	23,4	22,6	21,8	-
CL300	DIN EN 1759-1	48,1	42,3	38,6	35,8	33,5	31,6	30,4	29,3	-

NOTE:

At operating temperatures below -10 °C * a notch impact test must be performed according to **AD2000 Merkblatt W10 ****, in which the lowest temperatures are mentioned in three categories (**I, II, III**) for the respective usage cases.

Category **I** (allowed Temperature **Ts** at 100% of allowed Operating Pressure **Ps**)

Category **II** (allowed Temperature **Ts** at 75% of allowed Operating Pressure **Ps**)

Category **III** (allowed Temperature **Ts** at 25% of allowed Operating Pressure **Ps**)

Body Material	I	II	III
Cast Iron EN-JL1040	-10°C	-	-
Ductile Iron EN-JS1025	-10°C	-40°C	-
Carbon Steel 1.0619 (ASTM A216 WCB)	-10°C	-60°C	-85°C
Alloy Steel 1.7379 (ASTM A217 WC9)	-10°C	-60°C	-85°C
Carbon Steel 1.6220 (A352 LCB)	-40°C	-90°C	-120°C
Stainless Steel 1.4408 (ASTM A351 CF8M)	-200°C	-255°C	-270°C

* For low temperature usage a technical review of the manufacturer is required!

** The temperature limits mentioned in AD2000 Merkblatt W10 are purely theoretical values and relate only to the indicated material. Due to the multiplicity of used components - of a control valve - it also requires a separate review of the manufacturer!

Table 6a Flow Ratios [KV_s]

KV _s [m ³ /h]			Stroke [mm]	Ø Seat D [mm]	F _D [kN]		Nominal Diameter DN																
L	P	S			Class IV	Class VI	15	20	25	32	40	50	65	80	100	125	150	200	250				
0,010			20	6,35	0,1	0,16																	
0,016																							
0,025																							
0,040																							
0,063																							
0,10																							
0,16																							
0,25																							
0,40																							
0,63																							
1,0																							
1,6																							
2,5					9,52	0,15	0,25																
4,0					12,7	0,2	0,3																
6,3				19,05	0,3	0,5																	
10				20,64	0,35	0,5																	
16				25,25	0,4	0,6																	
25				31,72	0,5	0,8																	
40				41,25	0,7	1,0																	
63			38	50,8	0,8	1,3																	
94				66,7	1,1	1,7																	
125				88,9	1,4	2,2																	
160																							
250			50	107,92	1,7	2,7																	
320				126,95	2,0	3,2																	
500			63	158,72	2,5	4,0																	
630				195	3,1	4,9																	
Coefficients:			F _L = 0,9; X _T = 0,72; F _D = 0,46; xF _Z = 0,65																				

Table 6b Flow Ratios [KV_s] for balanced Plug

KV _s [m ³ /h]			Stroke [mm]	Ø Seat D [mm]	F _D [kN]		Nominal Diameter DN													
L	P	S			Class IV	Class VI	40	50	65	80	100	125 ¹⁾	150	200	250					
25			20	31,72	0,5	0,8														
40				41,25	0,7	1,0														
63			38	50,8	0,8	1,3														
94				66,7	1,1	1,7														
125				88,9	1,4	2,2														
160																				
250			50	126,95	1,7	2,7														
320					2,0	3,2														
500			63	158,72	2,5	4,0														
630				195	3,1	4,9														

NOTE: In Table 7 indicated pressure drops are based on closed control valve position and should not exceed 70% of allowable operating pressure for given nominal pressure, material execution and operating temperature as per Table 5.

Theoretical acceptable pressure drops are included. Actual pressure drops with consideration of tolerance of spring manufacture and friction of internal parts of the actuator are lower than those given by 20%.

Formula for calculation of ...

... allowable pressure drop:

$$\Delta p = \frac{F_s + F_D}{0,785 * 10^{-4} * D^2}$$

... needed force[kN]:

$$F_s = 0,785 * 10^{-4} * D^2 * \Delta p + F_D$$

For balanced valve plugs available force F_s at least equal to F_D value for soft valve seats in Table 6a should be adopted.

= possible

Table 7 Allowable Pressure Drops

KV _s [m ² /h]	DN	Stroke [mm]	Actuator Size [cm ²]	Metal Seated Class IV					Soft Seated Class VI						
				NO, Stem retract Spring Range 0,2...1,0 bar			NC, Stem extends		NO, Stem retract Spring Range 0,2...1,0 bar			NC, Stem extends			
				Δp [bar]			Spring Range		Δp [bar]			Spring Range			
1,4	2,5	4,0	Spring Range	Δp [bar]	1,4	2,5	4,0	Spring Range	Δp [bar]						
bis 4,0	15...50	20	250	40	-	-	0,2...1,0 0,4...1,2	23 40	35	-	-	0,2...1,0 0,4...1,2	15 35		
6,3	20...50			24	40	-	0,2...1,0 0,4...1,2 0,6...1,4	7 24 40	17	35	-	0,2...1,0 0,4...1,2 0,6...1,4	4 17 35		
10	25...50			20	40	-	0,2...1,0 0,4...1,2 0,6...1,4 0,8...2,4	5 20 34 40	12	35	-	0,2...1,0 0,4...1,2 0,6...1,4 0,8...2,4	3 12 26 35		
16	32...50			12	40	-	0,2...1,0 0,4...1,2 0,6...1,4 0,8...2,4 1,2...2,8	2 12 22 32 40	6	35	-	0,2...1,0 0,4...1,2 0,6...1,4 0,8...2,4 1,2...2,8	1 6 16 26 35		
	65			24	40	-	0,2...1,0 0,4...1,2 0,6...1,4	8 24 40	18	35	-	0,2...1,0 0,4...1,2 0,6...1,4	18 34 35		
25	40...80			400	14	40	-	0,2...1,0 0,4...1,2 0,6...1,4 0,8...2,4 1,2...2,8	4 14 24 34 40	10	35	-	0,2...1,0 0,4...1,2 0,6...1,4 0,8...2,4 1,2...2,8	2 10 20 30 35	
40	50...100							6,5	38	40	0,4...1,2 0,6...1,4 0,8...2,4 1,2...2,8	6 12 18 29	3,5	35	-
63	65...125			630	8,5	40	-	0,4...1,2 0,6...1,4 0,8...2,4 1,2...2,8 1,8...3,8	9 15 21 34 40	6	35	-	0,4...1,2 0,6...1,4 0,8...2,4 1,2...2,8 1,8...3,8	6 12 19 31 35	
	125; 150							1000	16	40	-	0,4...2,0 0,8...2,4 1,2...2,8	16 36 40	13	35
94	80...125			38	630	4	24	40	0,4...1,2 0,6...1,4 0,8...2,4 1,2...2,8 1,8...3,8	4 8 11 18 29	3	23	35	0,4...1,2 0,6...1,4 0,8...2,4 1,2...2,8 1,8...3,8	3 7 10 18 28
	125...200								1000	8	32	40	0,4...2,0 0,8...2,4 1,2...2,8 1,8...3,8	8 20 31 40	7
125; 160	100; 125			630	2	13	28	0,4...1,2 0,6...1,4 0,8...2,4 1,2...2,8 1,8...3,8	2 4 6 10 16	-	11	26	0,4...1,2 0,6...1,4 0,8...2,4 1,2...2,8 1,8...3,8	- 2 4 8 14	
	125...250	4	22					40	0,4...2,0 0,8...2,4 1,2...2,8 1,8...3,8	4 10 17 26	2,5	20	35	0,4...2,0 0,8...2,4 1,2...2,8 1,8...3,8	2 9 15 25
250	125...250	50	1000	2,5	14	30	0,4...2,0 0,8...2,4 1,2...2,8 1,8...3,8	2,5 6,5 11 17,5	1,2	13	29	0,4...2,0 0,8...2,4 1,2...2,8 1,8...3,8	1 5 10 16		
320	150...250						1,5	10	22	0,4...2,0 0,8...2,4 1,2...2,8 1,8...3,8	1,5 4,5 8 12,5	-	9	21	0,4...2,0 0,8...2,4 1,2...2,8 1,8...3,8
500	200; 250	63	1000	-	4	14	0,8...2,4 1,2...2,8 1,8...3,8	2,5 5 7,5	-	5	8	0,8...2,4 1,2...2,8 1,8...3,8	- 2 4 7		
630	250			-	4	9	0,8...2,4 1,2...2,8 1,8...3,8	1,5 3 5	-	3	8	0,8...2,4 1,2...2,8 1,8...3,8	1 2 4		

NOTE:
For actuators with NO function (Stem retract, spring range 0,2...1,0 bar), the supply pressure is indicated in table 7. Supply pressure must be min. 1,4 bar. For actuators with NC function (Stem extends) the supply pressure should be min. 0,4 bar higher than the upper spring range. E.g. supply pressure 2,8 bar at spring range 0,8...2,4 bar.

Pneumatic Actuator Type P/R (optional with top mounted handwheel type -N)

Features

completely reversibility - changing of operating mode P [NO] and R [NC] without any additional parts.

- » pneumatic connection ¼" NPT and ½" NPT
- » pipe diameter: Ø 6x1; Ø 8x1; Ø 10x1; Ø 12x1
- » ambient temperature: -30...+80°C
- » Spring range / no. of springs
 0,2...1,0 bar; 0,4...1,2 bar; 0,6...1,4 bar: 3 springs
 0,4...2,0 bar; 0,8...2,4 bar; 1,2...2,8 bar: 6 springs
 1,8...3,8 bar: 12 springs

No.	Component
1	actuator housing (pressure chamber)
2	
3	diaphragm (Neopren with Polyester inlay)
4	diaphragm plate
5	actuator stem
6	bearing and connection block
7	spring
8	distance bushing
9	distance spacer
10	warning label

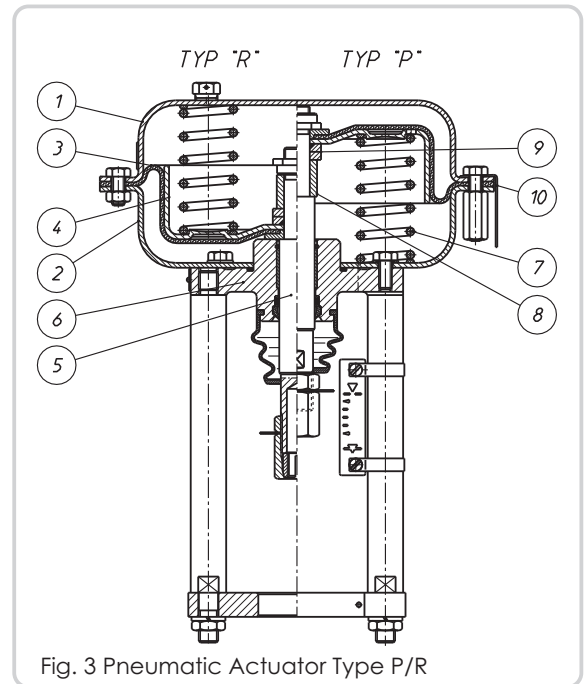

Fig. 3 Pneumatic Actuator Type P/R

Table 8 Actuator forces F_s [kN]

Size [cm ²]	max. allowable Supply Pressure [bar]	Type P (NO, Stem retract) Supply Pressure [bar]			Type R (NC, Stem extends) Spring Range [bar]						
		1,4	2,5	4,0	0,4...1,2		0,6...1,4	0,8...2,4	1,2...2,8	1,8...3,8	
					0,2...1,0	0,4...2,0					
250	6,0	1,0	3,8	7,5	0,5	1,0	1,5	2,0	3,0	-	
400		1,6	6,0	12	0,8	1,6	2,4	3,2	4,8	-	
630		2,5	9,5	18,9	1,3	2,5	3,8	5,0	7,6	11,3	
1000	5,0	4,0	15	30	2,0	4,0	6,0	8,0	12	18	

Table 9 Technical data for type P/R & PN/RN

Size	Diaphragm eff. area [cm ²]	Stroke [mm]	Weight [kg] (P/R)	Revolutions per Stroke (P/R-N)	Weight [kg] (P/R-N)
250	250	20	10	5	14,5
400	400		16		20,5
630	630	38	30	9	37
1000	1000	38; 50; 63	74	8; 10; 13	100

Table 10 Technical data for manual actuator type NN

Size	Stroke [mm]	Revolutions per Stroke	Weight [kg]
250	20	5	5,5
400			6,5
630	38	9	8,5
1000	38; 50; 63	8; 10; 13	40

Table 11 Valve Dimensions incl. Actuator [mm] and Weights excl. Actuator [kg]

DN	A			G				F								D				H					
	CL 150	CL 300	PN 10...40	Standard [mm]	Standard [kg]	Extended Bellows Seal [mm]	Extended Bellows Seal [kg]	P/R 250	P/R 400	P/R 630	P/R 1000	NN 250	NN 400	NN 630	NN 1000	P/R 250	P/R 400	P/R 630	P/R 1000		NN 250	NN 400	NN 630	NN 1000	
15		190	130		6		9																		
20	184	194	150	107	7	241	10																		
25		197	160		7,5		11																		
32	200	213	180	114	9,5	243	13																		
40	222	235	200	118	11,5	253	16																		
50	254	267	230	122	14,5	257	20																		162
65	276	292	290		20		28																		
80	298	318	310	166	28,5	410	36,5		312			290					305				225		305		
100	352	368	350	173	42	417	50			402			308					375							
125			400	255	80	450	95																		
150	451	473	480	305	120	510	135				585			510										450	240
200	543	568	600	458	180		195																		
250	673	708	730	475	320	623	335																		

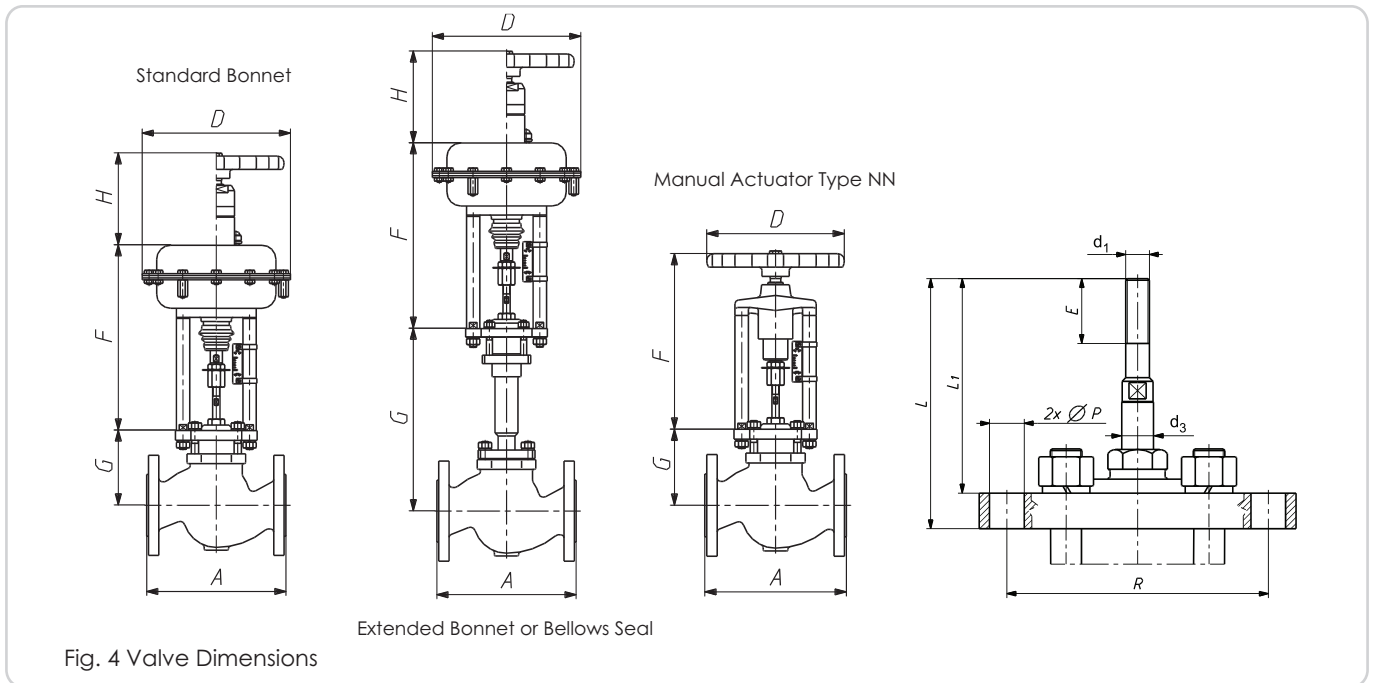

Table 12 Different F-t-F length due to flange facing

Body / Flange	Identification			A ₁
	DIN	ANSI		
Groove CL300	D1	GF		A ₁ = A + 5 * 2
Recess CL300	F1	FF		A ₁ = A + 5,5 * 2
Ring-Joint CL300 DN15	J	RTJ		A ₁ = A + 6,5 * 2
Ring-Joint CL150				
Ring-Joint CL300 DN20...40				
Ring-Joint CL300 DN50...250				
				A ₁ = A + 8 * 2

Table 13 Valve Connection

DN	d ₁	d ₃	E	L	L ₁	ØP	R	kN*
15...25	M12x1,25	12	44	125	111	12,5	110	13,5
32...50				118	102			
65...100		16	50	122	104	16,5	132	23
125...250		M16x1,5	20	80	138	118	24,5	216

NOTE:

- » R and ØP are customizable
- » Dimensions L and L₁ for Valve Position CLOSE

* To avoid buckling of the valve stem, the specified maximum forces should not be exceeded.