

Application

The High Performance Control Valves BR12a are used in automatic and remote control installations as flow control elements to adjust flow of liquids, steam and gases. Wide range of materials and design variants makes the valve applicable in most demanding working conditions in power generation, petroleum chemistry, heating, chemical industry, metallurgy and so on. The valve is to be used even under the most difficult operating conditions. Design and production meets the requirements of Quality Management System ISO 9001.

Features

- » Nominal Diameters from DN15 up to DN400
- » Nominal Pressure PN10 up to CL2500
- » Face-to-Face length as per DIN EN 60534-3-1 or ANSI/ISA 75.08
- » Temperature range -196°C up to +650°C
- » Leakage Class IV and V according to DIN EN 60534-4
- » Characteristik: Linear (L); Equal-percentage (P); ON/OFF [quick-opening] (S)
- » Rangeability 50:1
- » Design with Flange or Welding ends, TA-Luft, Bellows seal bonnet possible
- » Design as per Pressure Equipment Directive 2014/68/EU
- » Conformity CE and EAC
- » Optional certification/confirmation according to ATEX 2014/34/EU, GOST-R (TR), SIL2 (IEC 61508) and AD2000 Merkblatt

The various versions (multistage pressure reduction) serve to reduce noise and cavitation, reduce wear through flashing and eliminate chocked flow.

Design and technical Specification

Diameters: DN15; 20; 25; 40; 50; 80; 100; 150; 200; 250; 300*; 400*
* Special execution on request.

Pressure: PN10; 16; 25; 40 as per DIN EN 1092-1:2013 and DIN EN 1092-2:1997
PN63; 100; 160; 250; 320; 400 as per DIN EN 1092-1:2013
ANSI CL150; 300; 600; 900; 1500; 2500 as per DIN EN 1759-1:2005

Flanges as per DIN EN 1759-1:2005 can be assembled with flanges execution per standards ANSI / ASME B16.5 and MSS SP44. They correspond to the standard DIN EN 7005-1:2002 following pressure ranges
CL150 ≙ PN20; CL300 ≙ PN50; CL600 ≙ PN110; CL900 ≙ PN150; CL1500 ≙ PN260 und CL250 ≙ PN420

Table 1 Flange Versions

Nominal Pressure	Flange Facing			
	Raised Face	Groove	Recess	Ring-Joint
Identification				
PN10...400	B ³⁾	D1 ¹⁾	F ¹⁾	-
CL150...300		DL (D1 ²⁾)	F (F1 ¹⁾)	J (RTJ)
CL600...2500	B ³⁾ (RF)	DL (GF)	F (FF)	

1) up to PN160; 2) only CL300; 3) B1 - (Ra = 12,5 mm, concentric surface structure "C"), B2 - (Ra as agreed with the customer); () - as per ASME B16.5

Table 2 Packing and Bonnet Versions

Packing	PN / CL	Temperature [°C]		
		Standard	Valve Bonnet Extended	Bellows Seal ***
PTFE V-Ring	PN10 up to CL600	-46*...+200	-196*...-46* +200...+300	-100*...+200
PTFE+Graphite				
PTFE V-Ring / TA-Luft				
Graphite	PN10 up to CL2500	+200...+300	+300...+537 (+650**)	+200...+400
Graphite / TA-Luft				

* The use of a cryogenic bonnet is necessary from temperature as of -29°C! ** only with welding ends, *** Standard execution up to max. 35 bar



Body (1); Bonnet (2); Valve Plug (3); Valve Seat (4); Valve Stem (3a; 3b; 3c); Control Cage (6a);
 Choke Cage (6b; 6c); Body Gasket (7); Seat Gasket (8); Control Cage Gasket (9)

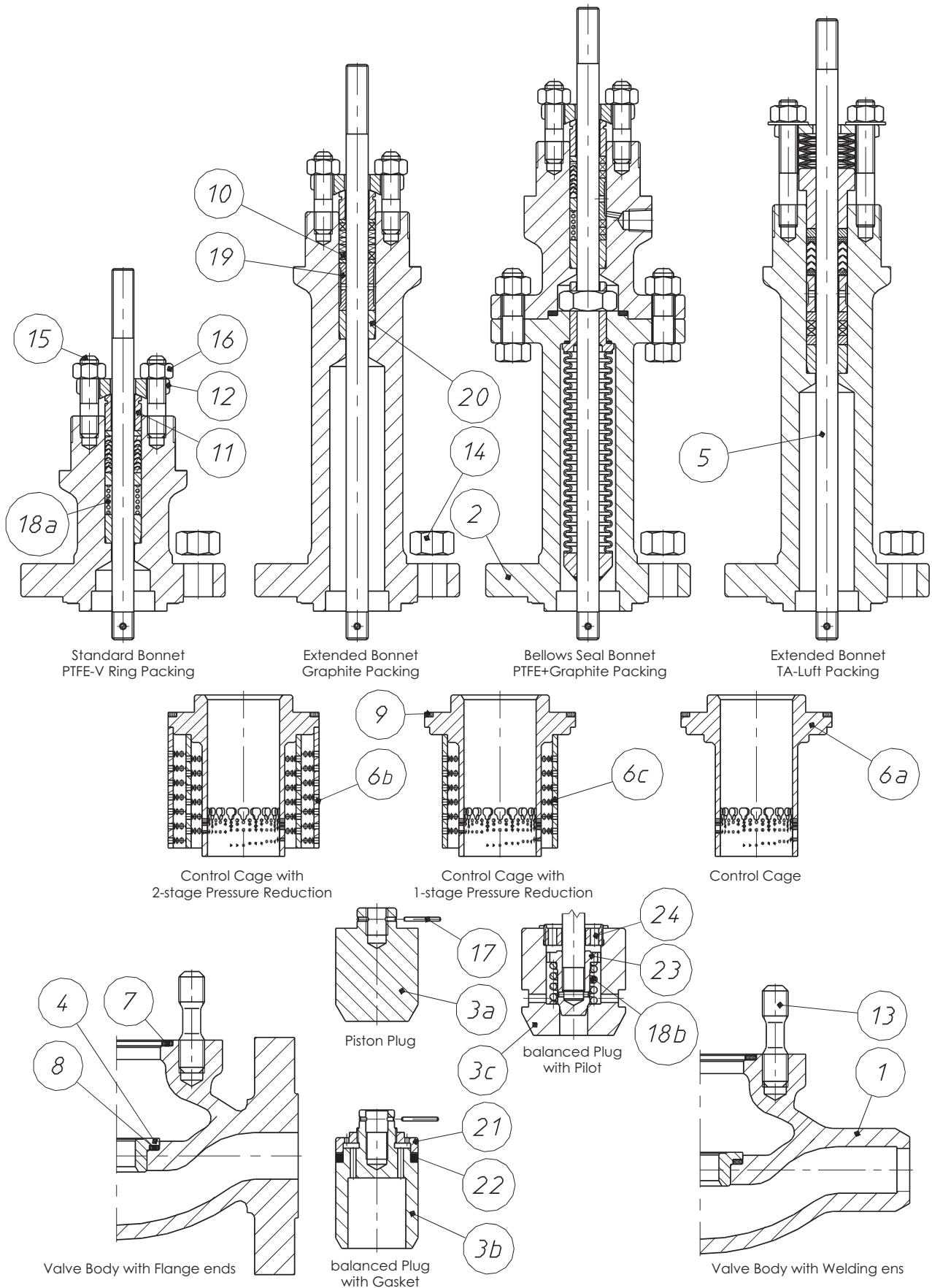

Fig. 1 Executions

NOTE: The control valves of series BR12b are recommended for application under heavy-duty working conditions, with excessive noise, flashing or choked flow. Selection of designs and materials depends on working conditions. It is based on computer-aided calculations of flow coefficients, noise level, fluid status, and effectiveness of such actions depends on data submitted by customer. Application of perforated control elements allows noise reduction by approx. 10 dBA regarding execution with contoured plug. Further noise reduction (~ 5 dBA) can be achieved by application of choke cage, which causes reduction in pressure drop between plug and seat. Such design is also recommended in case of choked flow, cavitation and flashing. Customers shall also appreciate possibility of achieving maximum flow ratio for all nominal sizes and control characteristics, and reduction in actuator costs due to application of balanced plugs.

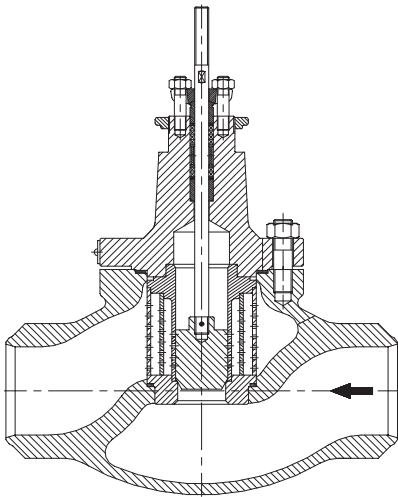

Fig. 1a Piston Plug with Control Cage and 2-stage Pressure Reduction

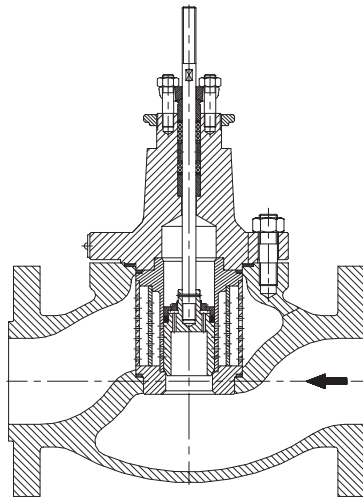

Fig. 1b balanced Plug with Gasket, Control Cage and 2-stage Pressure Reduction

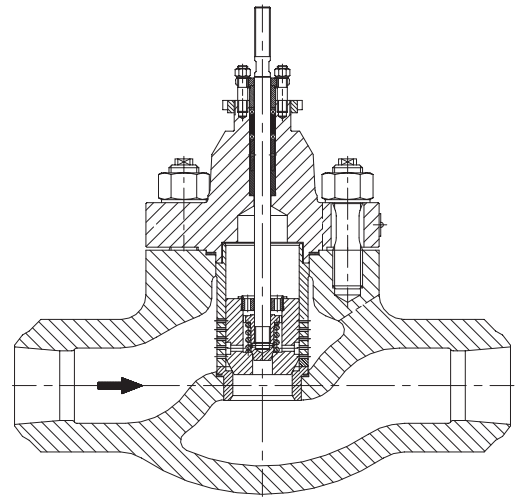
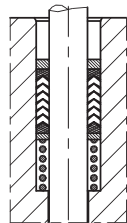
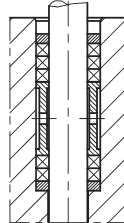

Fig. 1c balanced Plug with Pilot and Control Cage



PTFE-V Ring Packing



PTFE+Graphite Packing

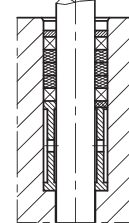

Graphite Packing

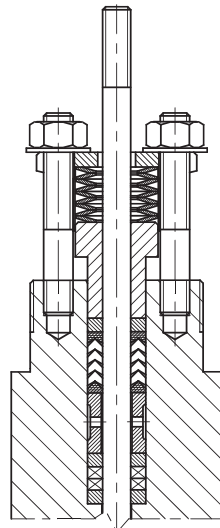

TA-Luft (PTFE-V Ring)

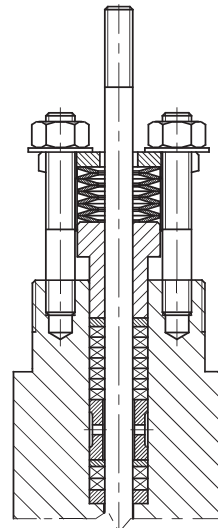

TA-Luft (Graphite)

Fig. 2 Types of Packing units

Table 3 Components and Materials

Nr.	Component		Material			
1	Body		GP240GH (1.0619) WCB	G20Mn5 (1.6220)	G17CrMo9-10 (1.7379) WC9	GX5CrNiMo19-11-2 (1.4408) CF8M
2	Bonnet	DN25...50	S355J2G3 (1.0570)		13CrMo4-4 (1.7335)	X6CrNiMoTi17-12-2 (1.4571)
		DN80...400	GP240GH (1.0619) WCB	G20Mn5 (1.6220)	G17CrMo9-10 (1.7379) WC9	
3	Plug		X6CrNiMoTi17-12-2 (1.4571) + Stellite + Chrom(III)-nitride X17CrNi 16-2 (1.4057) + heat treatment			
4	Seat		X6CrNiMoTi17-12-2 (1.4571) X6CrNiMoTi17-12-2 (1.4571) + Stellite X17CrNi 16-2 (1.4057) + heat treatment			
5	Stem		X6CrNiMoTi17-12-2 (1.4571) X6CrNiMoTi17-12-2 (1.4571) + Stellite + Chrom(III)-nitride X17CrNi 16-2 (1.4057) + heat treatment			
6a	Control cage		X6CrNiMoTi17-12-2 (1.4571) X17CrNi 16-2 (1.4057) + heat treatment			
6b; c	Choke cage					
7	Body gasket					
8	Seat gasket		Graphite (98%) + 1.4404 (Spiral)			
9	Control cage gasket					
10	Packing		PTFE+Graphite PTFE-V Ring Graphite			
11	Press Sleeve		X6CrNiMoTi17-12-2 (1.4571)			
12	Press Lever		S 355 JSG3 (1.0570)			
13	Body bolt	PN10...CL300	8.8			A4 – 70 *
		PN63...CL2500	42CrMo4 (1.7225)	21CrMoV5-7 (1.7709)	X6NiCrTiMoVB25-15-2 (1.4980)	
14	Body nut	PN10...CL300	8.8			A4 – 70 *
		PN63...CL2500	42CrMo4 (1.7225)	21CrMoV5-7 (1.7709)	X6NiCrTiMoVB25-15-2 (1.4980)	
15	Bonnet bolt		8.8			A4 – 70 *
16	Bonnet nut		8.8			A4 – 70 *
17	Notched peg		X6CrNiMoTi17-12-2 (1.4571)			
18a; b	Spring		12R10 (SANDVIK); 9Ru10 (1.4571 + SANDVIK); Nimonic 90 (2.4969)			
19	Spacer sleeve		X6CrNiMoTi17-12-2 (1.4571)			
20	Guide sleeve		X6CrNiMoTi17-12-2 (1.4571) + Stellite + Chrom(III)-nitride X17CrNi 16-2 (1.4057) + heat treatment			
21	Plug nut		X6CrNiMoTi17-12-2 (1.4571)			
22	Plug sealing ring		Expanded Graphite			
23	Pilot		X105CrMo17 (1.4125)			
24	Nut		X6CrNiMoTi17-12-2 (1.4571)			
•	Rec. Spare parts					

Material	Standard
GP240GH (1.0619)	DIN EN 10213-2
WCB	ASTM A 216
G20Mn5 (1.6220)	DIN EN 10213-3
G17CrMo9-10 (1.7379)	DIN EN 10213-2
WC9	ASTM A217
GX5CrNiMo19-11-2 (1.4408)	DIN EN 10213-4
CF8M	ASTM A351
S355J2G3 (1.0570)	DIN EN 10025
13CrMo4-4 (1.7335)	DIN EN 10028
X6CrNiMoTi17-12-2 (1.4571)	DIN EN 10088
X17CrNi16-2 (1.4057)	DIN EN 10088
X105CrMo17 (1.4125)	DIN EN 10088
C45 (1.0503)	DIN EN 10083-1
X30Cr13 (1.4028)	DIN EN 10088
8.8	EN 20898-1
A4-70 *	EN ISO 3506-2
42CrMo4 (1.7225)	EN 10269
21CrMoV5-7 (1.7709)	EN 10269
X6NiCrTiMoVB25-15-2 (1.4980)	EN 10269

* bei Normdruckstufe(n) PN10...CL600

- NOTE:**
- » Padding of Surface with Stellite: ~ 40HRC
 - » Chrom(III)-nitride Coating (~ 0,1 mm): ~ 950HV
 - » Heat treatment (quenched & tempered): Plug ~ 45HRC; Seat & Cages ~ 35HRC; Guiding Sleeve & Pilot ~ 45HRC

Table 4a...4d Allowable Operating Pressure (DIN)

Table 4a		Material: GP240GH (1.0619) as per DIN EN 10213-2													
PN / CL	Standard	Temperature [°C]													
		-10...+50	100	150	200	250	300	350	400	450	500	550	600	650	
		Max. Operating Pressure [bar]													
PN10	DIN EN 1092-1	10	9,2	8,8	8,3	7,6	6,9	6,4	5,9	-	-	-	-	-	
PN16		16	14,8	14	13,3	12,1	11	10,2	9,5	-	-	-	-	-	
CL150	DIN EN 1759-1	17,3	15,4	14,6	13,8	12,1	10,2	8,4	6,5	-	-	-	-	-	
PN25	DIN EN 1092-1	25	23,2	22	20,8	19	17,2	16	14,8	-	-	-	-	-	
PN40		40	37,1	35,2	33,3	30,4	27,6	25,7	23,8	-	-	-	-	-	
CL300	DIN EN 1759-1	45,3	40,1	38,1	36	32,9	29,8	27,8	25,7	-	-	-	-	-	
PN63	DIN EN 1092-1	63	58,5	55,5	52,5	48	43,5	40,5	37,5	-	-	-	-	-	
PN100		100	92,8	88	83,3	76,1	69	64,2	59,5	-	-	-	-	-	
CL600	DIN EN 1759-1	90,5	80,2	76,1	72	65,8	59,7	55,5	51,4	-	-	-	-	-	
CL900		136	120	114	108	98,7	89,5	83,3	77,1	-	-	-	-	-	
PN160	DIN EN 1092-1	160	148,5	140,9	133,3	121,9	110,4	102,8	95,2	-	-	-	-	-	
PN250		250	232,1	220,2	208,3	190,4	172,6	160,7	148,8	-	-	-	-	-	
CL1500	DIN EN 1759-1	226	201	190	180	165	149	139	129	-	-	-	-	-	
PN320	DIN EN 1092-1	320	297,1	281,9	266,6	243,8	220,9	205,7	190,4	-	-	-	-	-	
PN400		400	371,4	352,3	333,3	304,7	276,1	257,1	238	-	-	-	-	-	
CL2500	DIN EN 1759-1	377	334	317	300	274	249	231	214	-	-	-	-	-	

Table 4b		Material: G20Mn5 (1.6220) as per DIN EN 10213-3													
PN / CL	Standard	Temperature [°C]													
		-40	100	150	200	250	300	350	400	450	500	550	600	650	
		Max. Operating Pressure [bar]													
PN10	-	6	6	3,8	3,6	3,48	3,4	-	-	-	-	-	-	-	
PN16		16	16	10,1	9,6	9,28	9,07	-	-	-	-	-	-	-	
PN25		25	25	15,8	15	14,5	14,2	-	-	-	-	-	-	-	
PN40		40	28	28	27	26	25	-	-	-	-	-	-	-	
PN63		63	59	58	55	53	51	-	-	-	-	-	-	-	
PN100		100	95	92	87	85	82	-	-	-	-	-	-	-	
PN160		160	152	148	140	136	132	-	-	-	-	-	-	-	

Table 4c		Material: G17CrMo9-10 (1.7379) as per DIN EN 10213-2													
PN / CL	Standard	Temperature [°C]													
		-10...+50	100	150	200	250	300	350	400	450	500	550	600	650	
		Max. Operating Pressure [bar]													
PN10	DIN EN 1092-1	10	10	10	10	10	10	9,7	9,2	8,8	6,4	3,2	-	-	
PN16		16	16	16	16	16	16	16	15,6	14,8	14	10,2	5,1	-	-
CL150	DIN EN 1759-1	19,5	17,7	15,8	14	12,1	10,2	8,4	6,5	4,7	2,8	-	-	-	
PN25	DIN EN 1092-1	25	25	25	25	25	25	24,4	23,2	22	16	8	-	-	
PN40		40	40	40	40	40	40	39	37,1	35,2	25,7	12,9	-	-	
CL300	DIN EN 1759-1	51,7	51,5	50,2	48,3	46,3	42,8	40,2	36,6	33,8	28,2	15,5	-	-	
PN63	DIN EN 1092-1	63	63	63	63	63	63	61,5	58,5	55,5	40,5	20,4	-	-	
PN100		100	100	100	100	100	100	97,6	92,8	88	64,2	32,3	-	-	
CL600	DIN EN 1759-1	103	103	100	96,7	92,6	85,7	80,4	73,1	67,6	56,4	31,1	-	-	
CL900		155	155	151	145	139	129	121	110	101	84,6	46,6	-	-	
PN160	DIN EN 1092-1	160	160	160	160	160	160	156,1	148,5	140,9	102,8	51,8	-	-	
PN250		250	250	250	250	250	250	244	232,1	220,2	160,7	80,9	-	-	
CL1500	DIN EN 1759-1	259	258	251	242	232	214	201	183	169	141	77,7	-	-	
PN320	DIN EN 1092-1	320	320	320	320	320	320	312,3	297,1	281,9	205,7	103,6	-	-	
PN400		400	400	400	400	400	400	390,4	371,4	352,3	257,1	129,5	-	-	
CL2500	DIN EN 1759-1	431	429	418	403	386	357	335	305	282	235	130	-	-	

Table 4d		Material: GX5CrNiMo19-11-2 (1.4408) as per DIN EN 10213-4													
PN / CL	Standard	Temperature [°C]													
		-10...+50	100	150	200	250	300	350	400	450	500	550	600	650	
		Max. Operating Pressure [bar]													
PN10	DIN EN 1092-1	10	10	9	8,4	7,9	7,4	7,1	6,8	6,7	6,6	6,5	5,6	-	
PN16		16	16	14,5	13,4	12,7	11,8	11,4	10,9	10,7	10,5	10,4	8,9	-	
CL150	DIN EN 1759-1	17,9	16,3	14,9	13,5	12,1	10,2	8,4	6,5	4,7	2,8	-	-	-	
PN25	DIN EN 1092-1	25	25	22,7	21	19,8	18,5	17,8	17,1	16,8	16,5	16,3	14	-	
PN40		40	40	36,3	33,7	31,8	29,7	28,5	27,4	26,9	26,4	26	22,4	-	
CL300	DIN EN 1759-1	46,7	42,5	38,9	35,3	32,9	30,5	28,8	27,6	26,9	26,4	22,2	-	-	
PN63	DIN EN 1092-1	63	63	57,3	53,1	50,1	46,8	45	43,2	42,4	41,7	41,1	35,4	-	
PN100		100	100	90,9	84,2	79,5	74,2	71,4	68,5	67,3	66,1	65,2	56,1	-	
CL600	DIN EN 1759-1	93,4	85	77,8	70,6	65,8	61	57,6	55,2	53,8	52,8	44,4	-	-	
CL900		140	127	117	106	98,6	91,4	86,4	82,8	80,6	79,2	66,7	-	-	
PN160	DIN EN 1092-1	160	160	145,5	134,8	127,2	118,8	114,2	109,7	107,8	105,9	104,3	89,9	-	
PN250		250	250	227,3	210,7	198,8	185,7	178,5	171,4	168,4	165,4	163	140,4	-	
CL1500	DIN EN 1759-1	233	212	194	176	164	152	144	138	134	132	111	-	-	
PN320	DIN EN 1092-1	320	320	291	269,7	254,4	237,7	228,5	219,4	215,6	211,8	208,7	179,8	-	
PN400		400	400	363,8	337,1	318	297,1	285,7	274,2	269,5	264,7	260,9	224,7	-	
CL2500	DIN EN 1759-1	389	354	324	294	274	254	240	230	224	220	185	-	-	

High-Performance Control Valve

BR12b

Table 4e...4g Allowable Operating Pressure (ASTM)

Table 4e		Material: WCB as per ASTM A216													
PN / CL	Standard	Temperature [°C]													
		-10...+50	100	150	200	250	300	350	400	450	500	550	600	650	
		Max. Operating Pressure [bar]													
PN10	DIN EN 1092-1	10	10	9,7	9,4	9	8,3	7,9	6,7	-	-	-	-	-	
PN16		16	16	15,6	15,1	14,4	13,4	12,8	10,8	-	-	-	-	-	
CL150	DIN EN 1759-1	19,3	17,7	15,8	14	12,1	10,2	8,4	6,5	-	-	-	-	-	
PN25	DIN EN 1092-1	25	25	24,4	23,7	22,5	20,9	20	16,9	-	-	-	-	-	
PN40		40	40	39,1	37,9	36	33,5	31,9	27	-	-	-	-	-	
CL300	DIN EN 1759-1	50	46,4	45,1	43,9	41,8	38,9	36,9	34,6	-	-	-	-	-	
PN63	DIN EN 1092-1	63	63	61,5	59,6	56,8	52,7	50,3	42,5	-	-	-	-	-	
PN100		100	100	97,7	94,7	90,1	83,6	79,8	67,5	-	-	-	-	-	
CL600	DIN EN 1759-1	100,1	92,8	90,6	87,8	83,6	77,5	74	69,1	-	-	-	-	-	
CL900		150,1	139,2	135,7	131,4	125,1	116,1	110,8	103,4	-	-	-	-	-	
PN160	DIN EN 1092-1	159,2	147,6	143,9	139,4	132,7	123,1	117,5	109,7	-	-	-	-	-	
PN250		241,4	223,5	217,8	211,2	201,1	186,6	178,1	166,2	-	-	-	-	-	
CL1500	DIN EN 1759-1	250,5	231,9	226	219,2	208,7	193,6	184,8	172,5	-	-	-	-	-	
PN320	DIN EN 1092-1	313	289,9	282,6	273,9	260,8	242	231	215,6	-	-	-	-	-	
PN400		396,4	367,3	358	346,9	330,3	306,6	292,6	273,1	-	-	-	-	-	
CL2500	DIN EN 1759-1	417,2	386,6	376,9	365,1	347,7	322,7	308	287,5	-	-	-	-	-	

Table 4f		Material: WC9 as per ASTM A217													
PN / CL	Standard	Temperature [°C]													
		-10...+50	100	150	200	250	300	350	400	450	500	550	600	650	
		Max. Operating Pressure [bar]													
PN10	DIN EN 1092-1	10	10	10	10	10	10	10	9,9	9,5	5,5	2,9	-	-	
PN16		16	16	16	16	16	16	16	16	15,9	15,3	8,9	4,7	-	
CL150	DIN EN 1759-1	19,5	17,7	15,8	14	12,1	10,2	8,4	6,5	4,6	2,8	-	-	-	
PN25	DIN EN 1092-1	25	25	25	25	25	25	25	24,8	23,9	14	7,4	-	-	
PN40		40	40	40	40	40	40	40	39,7	38,3	22,3	12	-	-	
CL300	DIN EN 1759-1	51,7	51,5	50,3	48,7	46,3	42,9	40,4	36,5	33,7	27,7	15,3	-	-	
PN63	DIN EN 1092-1	63	63	63	63	63	63	63	62,5	60,3	35,2	18,8	-	-	
PN100		100	100	100	100	100	100	100	99,2	95,6	55,9	29,9	-	-	
CL600	DIN EN 1759-1	103,4	103,1	100,3	97,5	92,7	85,7	80,4	73,3	67,7	55,7	30,7	-	-	
CL900		155,1	154,6	150,6	146,2	139	128,6	120,7	109,8	101,4	83,4	46	-	-	
PN160	DIN EN 1092-1	164,5	163,9	159,5	154,7	147,4	136,4	128	116,5	107,6	87,3	48,8	-	-	
PN250		249,2	248,1	239,8	231,2	222,6	206,6	193,8	176,4	162,9	122,2	74,1	-	-	
CL1500	DIN EN 1759-1	258,6	257,7	250,8	244	231,8	214,4	201,1	183,1	169,1	138,9	76,9	-	-	
PN320	DIN EN 1092-1	323,2	321,9	312,3	302,3	289,2	268	251,4	228,8	211,4	165,7	96	-	-	
PN400		409,4	408	397,1	385,7	366,8	339,4	318,5	389,7	267,7	218,5	121,5	-	-	
CL2500	DIN EN 1759-1	430,9	429,5	418,3	406,5	386,2	357,2	335,3	304,9	281,8	231,7	127,9	-	-	

Table 4g		Material: CF8M as per ASTM A351													
PN / CL	Standard	Temperature [°C]													
		-10...+50	100	150	200	250	300	350	400	450	500	550	600	650	
		Max. Operating Pressure [bar]													
PN10	DIN EN 1092-1	8,9	7,8	7,1	6,6	6,1	5,8	5,6	5,4	5,3	5,2	5,1	3,8	-	
PN16		14,3	12,5	11,4	10,6	9,8	9,3	9	8,7	8,5	8,4	8,2	6,1	-	
CL150	DIN EN 1759-1	18,4	16	14,8	13,6	12	10,2	8,4	6,5	4,6	2,8	-	-	-	
PN25	DIN EN 1092-1	22,3	19,5	17,8	16,5	15,5	14,6	14,1	13,6	13,4	13,2	12,9	9,6	-	
PN40		35,6	31,3	28,5	26,4	24,7	23,4	22,6	21,8	21,4	21	20,7	15,5	-	
CL300	DIN EN 1759-1	48,1	42,3	38,6	35,8	33,5	31,6	30,4	29,3	29	27,3	24	19,9	11,8	
PN63	DIN EN 1092-1	56,1	49,2	44,9	41,6	38,9	36,9	35,5	34,4	33,7	33,2	32,6	24,4	-	
PN100		89,1	78,1	71,3	66	61,8	58,5	56,4	54,5	53,4	52,6	51,7	38,7	-	
CL600	DIN EN 1759-1	96,3	84,5	77,1	71,2	66,7	63,1	61	58,9	57,7	54,8	47,8	39,8	24,5	
CL900		144,4	126,8	115,6	107	100,2	95	91,3	88,2	86,6	82,1	71,8	59,7	37,3	
PN160	DIN EN 1092-1	153,1	134,4	122,6	113,5	106,3	100,7	96,8	93,6	91,8	87,1	76,2	63,3	39,3	
PN250		231,9	203,3	185,4	171,9	160,9	152,4	146,7	141,7	139,1	131,7	115,4	95,9	60	
CL1500	DIN EN 1759-1	240,6	210,9	192,4	178,4	167	158,1	152,2	147,1	144,3	136,7	119,8	99,5	62,8	
PN320	DIN EN 1092-1	300,8	263,7	240,6	223	208,7	197,6	190,3	184	180,3	170,9	149,7	124,4	78,2	
PN400		381	334,1	304,8	282,4	264,2	250,3	241,1	233,1	228,4	216,6	189,5	157,7	99,4	
CL2500	DIN EN 1759-1	401	351,7	320,8	297,2	278,1	263,5	253,8	245,4	240,4	228	199,5	166	105,5	

NOTE:

At operating temperatures below -10°C* a notch impact test must be performed according to **AD2000 Merkblatt W10 ****, in which the lowest temperatures are mentioned in three categories (I, II, III) for the respective usage cases.

Category I (allowed Temperature **Ts** at 100% of allow Operating Pressure **Ps**)

Category II (allowed Temperature **Ts** at 75% of allow Operating Pressure **Ps**)

Category III (allowed Temperature **Ts** at 25% of allow Operating Pressure **Ps**)

* For low temperature usage a technical review of the manufacturer is required!

** The temperature limits mentioned in AD2000 Merkblatt W10 are purely theoretical values and relate only to the indicated material. Due to the multiplicity of used components - of a control valve - it also require a separate review of the manufacturer!

Table 5 Flow Ratios [KVs]

KVs [m³/h]		Stroke Ø Seat D [mm]	F _b [kN]	Nominal Diameter DN											
L	P			Class IV	Class V	25	40	50	80	100	150	200	250		
10	20	20,64	0,35	2,1	K1**	K2	K2							> DN250 Special Execution	
16		25,25	0,4	2,6		K1	K2								
25		31,72	0,5	3,3		K1	K1	K2							
40	38	41,25	0,7	4,6			K1	K2	K2						
63		50,8	0,8	5,2				K1	K2	K2					
94		66,7	1,1	7,2				K0	K1	K2	K2				
125	50	88,9	1,4	9,1				K1	K2	K2	K2				
160								K1	K2	K2	K2				
200	63	107,92	1,7	11					K1	K2	K2				
250									K1	K2	K2				
320	80	126,95	2,0	13					K1	K2	K2				
500	100	158,72	2,5	16							K1	K2			
630		203,2	3,2	21									K1		
800	-												K1		
Coefficients :		F _L =0,95; X _r =0,78; F _d =0,1; xF _z =0,75			no Version for PN250...CL2500										
					** K0 for Nominal Pressure PN10...CL300										
					K0...2 Maximum numbers of cages										

NOTE: In Table 7 indicated pressure drops are based on closed control valve position and should not exceed 70% of allowable operating pressure for given nominal pressure, material execution and operating temperature as per Table 4.

Theoretical acceptable pressure drops are included. Actual pressure drops with consideration of tolerance of spring manufacture and friction of internal parts of the actuator are lower than those given by 20%.

- » Balanced Valve Plug with Gasket only possible in Leakage Class IV.
Application range: DN25...400; max. CL2500; max. 500°C
- » Balanced Valve Plug with Pilot are not allowed to be used for aggressive media.
Application range: DN50...400; max. CL600; max. 540°C

Formula for calculation of ... allowable pressure drop:
$$\Delta p = \frac{F_s + F_D}{0,785 * 10^{-4} * D^2}$$

= possible ... needed force [kN]:
$$F_s = 0,785 * 10^{-4} * D^2 * \Delta p + F_D$$

Table 6 Actuator forces F_s [kN]

Size [cm²]	max. allowable Supply Pressure [cm²]	Type P; P1 (NO, Stem retract) Supply Pressure [bar]			Type R; R1 (NC, Stem extends) Spring Range [bar]						
		1,4	2,5	4,0	0,2...1,0	0,4...1,2 0,4...2,0	0,6...1,4	0,8...2,4	1,2...2,8	1,8...3,8	
250	6,0	1,0	3,8	7,5	0,5	1,0	1,5	2,0	3,0	-	
400		1,6	6,0	12	0,8	1,6	2,4	3,2	4,8	-	
630		2,5	9,5	18,9	1,3	2,5	3,8	5,0	7,6	11,3	
R-630T	5,0	-	-	-	2,6	5,0	7,6	10	15,2	22,6	
1000		4,0	15	30	2,0	4,0	6,0	8,0	12	18	
1500		6,0	22,5	45	3,0	6,0	9,0	12	18	27	
1500T		12	45	90	6,0	12	18	24	36	54	

NOTE: For actuators with NO function (Stem retract, spring range 0,2...1,0 bar), the supply pressure is indicated in table 7. Supply pressure must be min. 1,4 bar. For actuators with NC function (Stem extends) the supply pressure should be min. 0,4 bar higher than the upper spring range. E.g. supply pressure 2,8 bar at spring range 0,8...2,4 bar.

High-Performance Control Valve

BR12b

Table 7 Allowable Pressure Drops

Ø Seat D [mm]	Size [cm ²]	NO, Stem retract						NC, Stem extends											
		Class IV			Class V			Class IV						Class V					
		Supply Pressure [bar]						Supply Pressure [bar]											
(Spring Range 0.2...1.0 bar)						Δp [bar]													
		1,4	2,5	4,0	1,4	2,5	4,0	0,2...1,0	0,4...1,2 4,0...2,0	0,6...1,4	0,8...2,4	1,2...2,8	1,8...3,8	0,2...1,0	0,4...1,2 4,0...2,0	0,6...1,4	0,8...2,4	1,2...2,8	1,8...3,8
20,64	250	20	100	210	-	48	159	5	20	34	49	78	-	-	-	-	26	-	
	400	37	166	280	-	115	280	14	37	60	84	131	-	-	9	32	79	-	
	630	65	272	280	11	218	280	27	65	103	140	216	280	-	11	49	86	162	274
	R-630T	-	-	-	-	-	-	65	140	216	280	280	280	11	86	162	237	280	280
25,25	250	12	67	142	-	23	98	2	12	22	32	52	-	-	-	-	8	-	
	400	24	112	232	-	68	188	8	24	40	56	88	-	-	-	12	44	-	
	630	42	180	280	-	136	280	17	42	67	92	143	218	-	-	23	48	98	174
	R-630T	-	-	-	-	-	-	42	92	143	193	280	280	-	48	98	149	249	280
31,72	250	6	41	88	-	5	53	-	6	12	19	31	-	-	-	-	-	-	
	400	14	70	145	-	34	110	4	14	24	34	54	-	-	-	-	19	-	
	630	25	113	232	-	78	197	10	25	41	57	90	137	-	-	6	21	54	101
	R-630T	-	-	-	-	-	-	25	57	89	121	185	280	-	22	54	85	149	245
41,25	630	13	63	130	-	35	102	4	13	22	31	49	75	-	-	-	3	21	48
	R-630T	-	-	-	-	-	-	14	32	51	70	108	164	-	5	24	43	81	137
50,8	630	9	43	90	-	21	69	2,5	9	15	21	34	53	-	-	-	-	12	30
	1000	16	71	146	-	49	124	6	16	26	36	56	86	-	-	4	14	34	64
	1500	25	107	218	3	85	196	10	25	40	55	84	129	-	3	18	33	62	107
66,7	630	4	24	50	-	6	33	-	4	8	11	18	29	-	-	-	-	-	11
	1000	8	40	83	-	22	65	3	8	14	20	31	48	-	-	-	2	14	30
	1500	14	61	125	-	44	108	5	14	23	31	48	74	-	-	5	14	30	56
88,9	1000	4	22	46	-	10	34	-	4	7	11	17	27	-	-	-	-	5	14
	1500	7	34	70	-	21	58	3	7	12	17	27	41	-	-	-	5	14	29
107,92	1000	3	14	30	-	4	20	-	3	5	7	11	18	-	-	-	-	-	8
	1500	5	23	47	-	13	37	-	5	8	11	18	28	-	-	-	-	8	17
	1500T	11	48	96	-	37	86	5	11	18	24	37	57	-	-	8	14	27	47
126,95	1500	3	16	34	-	8	25	-	3	6	8	13	20	-	-	-	-	4	11
	1500T	8	34	70	-	25	61	3	8	13	17	27	41	-	-	4	9	18	33
158,72	1500	2	10	21	-	3	14	-	2	3	5	8	12	-	-	-	-	-	6
	1500T	5	21	44	-	14	37	2	5	8	10	17	26	-	-	-	4	10	19
203,2	1500	-	6	13	-	-	7	-	-	2	3	4,5	7	-	-	-	-	-	2
	1500T	3	13	27	-	7	21	-	3	4,5	6	10	16	-	-	-	-	5	10

Table 8 Valve Connection

DN	KVs	Stroke [mm]	d ₁	d ₂	d ₃	kN *
25...50	10...25	20	M12x1,25	57,15	12	13,5
50	40	38				
80	25	20				
80;100	40	38	M16.1,5	84,15	16	23
	63; 94					
100	125; 160	50				
150	63; 94	38	M20x1,5	95,25	20	38
	125; 160	50				
	200; 250	63				
200	320	80	M16x1,5	95,25	24	64
	94	38				
200; 250	125; 160	50				
	200; 250	63				
	320	80	M24x1,5			
	500	10				
250	630; 800					

NOTE: Specified KVs-values are in version with Contoured plug. For Nominal Diameter DN80 and DN100 with TA-Luft bonnet d₂ = 84,15
 * To avoid buckling of the valve stem, the specified maximum forces should not be exceeded.

Table 9 Valve Dimensions [mm] and Weights [kg]

DN	PN/CL	B max	C		Bellows Seal	Weight [kg]
			Standard	Extended		
25	PN10...CL300	63	135	306	254	8
	PN63...CL600	70				
	CL900...PN160	75	149	320		8,5
	PN250...CL1500					
	PN320	80	193	364	-	9,5
PN400...CL2500						
40	PN10...CL300	75	145	316	254	15,5
	PN63...CL600	85				
	CL900...PN160	93	172	348	-	17,5
	PN250...CL1500					
	PN320	98	214	385	-	20
PN400...CL2500						
50	PN10...CL300	83	155	326	270	22
	PN63...CL600	98				
	CL900...PN160	108	175	345	-	25
	PN250...CL1500					
	PN320	105	237	402	-	31
PN400...CL2500						
80	PN10...CL300	105	206	375	405	40
	PN63...CL600	145				
	CL900...PN160	120	233	402	-	43
	PN250...CL1500					
	PN320	138	257	447	-	50
PN400...CL2500						
100	PN10...CL300	128	217	407	405	65
	PN63...CL600	138				
	CL900...PN160	145	252	442	-	72
	PN250...CL1500					
	PN320	168	329	498	-	86
PN400...CL2500						
150	PN10...CL300	160	287	426	470	132
	PN63...CL600	178				
	CL900...PN160	190	365	483	-	147
200	PN10...CL300	190	439	539	580	195
	PN63...CL600	235				
250	PN10...CL300	258	458	558	580	320
	CL300 (KV's 800)					
	PN63...CL600	255	-	-	660	330

NOTE: Valve weights with standard bonnet, exclusive actuator!

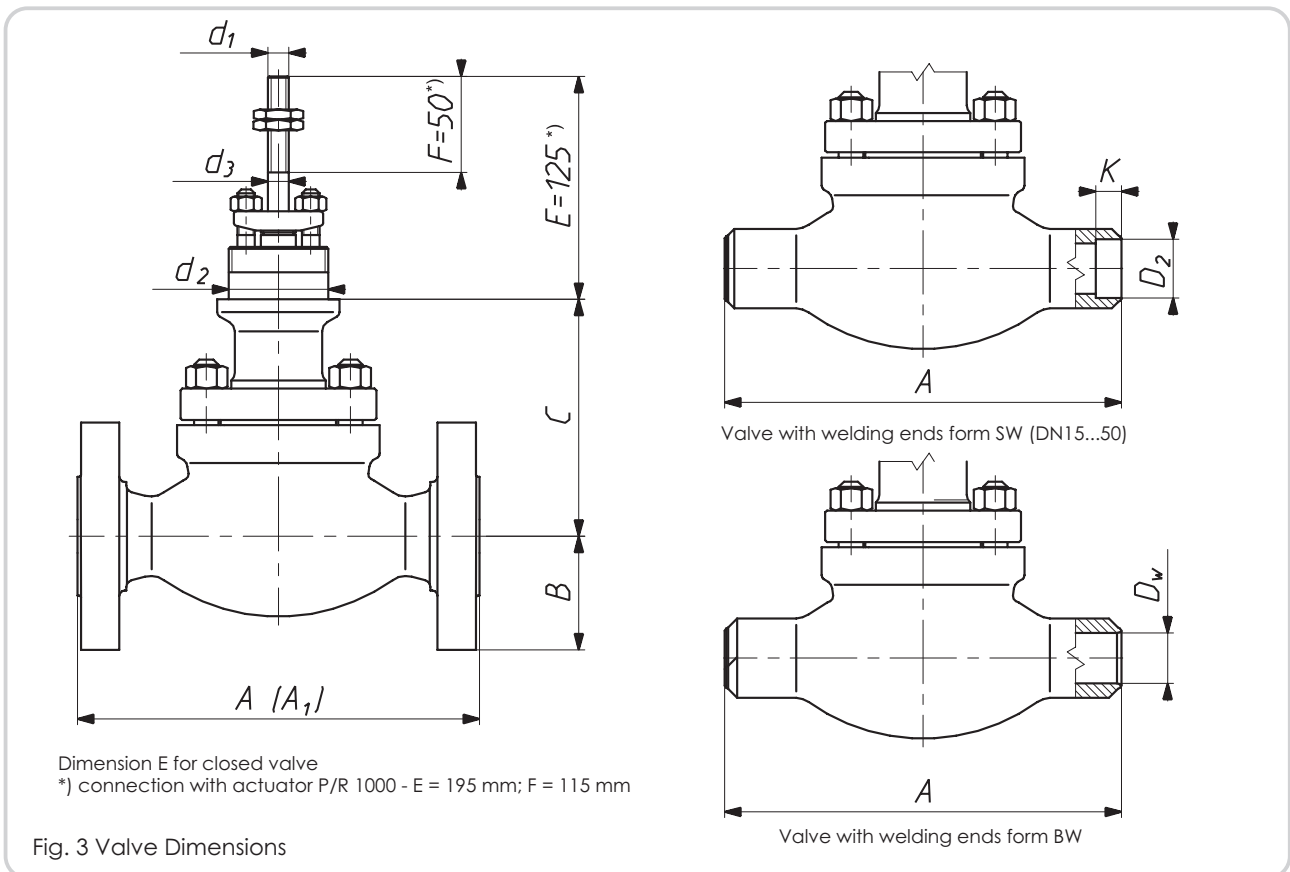

Table 10a Face-to-Face length [mm] with flange ends

DN	Dimension A [mm]										
	PN 10...40	PN 63...100	PN 160	PN 250; 320	PN 400	CL 150	CL 300	CL 600	CL 900	CL 1500	CL 2500
25	160	230	260	300	184	197	210	248	273	308	
40	200	260	300	350	222	235	251	270	311	359	
50	230	300	350	400	254	267	286	311	340	400	
80	310	380	450	500	298	318	337	387	460	498	
100	350	430	520	580	352	368	394	464	530	575	
150	480	550	-	-	451	473	508	556	-	-	
200	600	650	-	-	543	568	610	-	-	-	
250	730	775	-	-	673	708	752	-	-	-	
> 250	Special Execution		-	-	-	Special Execution		-	-	-	

Table 10b Different Face-to-Face [mm] due to flange facing

Identification DIN (ANSI)	Pressure CL	Diameter DN	A ₁
Groove DL (GF) or Recess F (FF)	CL300	15...250	$A_1 = A + 5 * 2$
	CL600		$A_1 = A - 1,5 * 2$
	CL900		
	CL1500 CL2500		
Ring-Joint J (RTJ)	CL300	15	$A_1 = A + 5,5 * 2$
	CL150	20...40	$A_1 = A + 6,5 * 2$
		15...250	
	CL300	50...250	$A_1 = A + 8 * 2$
	CL600 CL900 CL1500	15...40	$A_1 = A$
		CL2500	
		15...25	
	CL600 CL900 CL1500	50...250	$A_1 = A + 1,5 * 2$
		CL900	
		CL1500	
CL2500	40...50	$A_1 = A + 1,5 * 2$	
	CL900		
CL900 CL2500	150	$A_1 = A + 3 * 2$	
	80	$A_1 = A + 4,5 * 2$	
CL2500	100	$A_1 = A + 4,5 * 2$	

Table 11 Face-to-Face length [mm] with welding ends

DN	Form SW ^(EN 12760)		Dimension A [mm]		
	D ₂	K	PN10...CL600	CL900...PN160	PN250...CL2500
25	34	13	210	230	300
40	47,7		251	260	350
50	61	16	286	300	400
80	-		-	337	380
100		394		430	580
150		508		550	-
200		610		-	-
250		752		-	-
> 250		Special Execution		-	-

Table 12a Dimensions [mm] for welding ends form BW

DN	D _z	t	D _w	DIN (EN 12627)											
				10	16	25	40	63	100	160	250	320	400		
25	33,7	2,6	28,5	x	x	x	x	x	x						
		2,9	27,9							x					
		3,6	26,5								x				
		5	23,7									x			
		7,1	19,5										x		
42,4												x			
40	48,3	2,6	43,1	x	x	x	x								
		2,9	42,5					x	x						
		3,6	41,1							x					
		5	38,3								x				
		6,3	35,7									x			
10	28,3										x				
50	60,3	2,9	54,5	x	x	x	x	x							
		3,2	53,9						x						
		4	52,3							x					
		6,3	47,7								x				
		8	44,3									x			
12,5	35,3										x				
80	88,9	3,2	82,5	x	x	x	x								
		3,6	81,7					x							
		4	80,9						x						
		6,3	76,3							x					
		11	66,9								x				
12,5	63,9									x					
17,5	53,9										x				
114,3												x			
100	114,3	3,6	107,1	x	x	x	x								
		4	106,3					x							
		5	104,3						x						
		8	98,3							x					
		14,2	85,9								x				
16	82,3									x					
22,2	69,9										x				
139,7												x			
150	168,3	4,5	159,3	x	x	x	x								
		5,6	157,1					x							
		7,1	154,1						x						
12,5	143,3							x							
193,7												x			
200	219,1	5,9	207,3	x	x										
		6,3	206,5			x	x								
		7,1	204,9					x							
		10	199,1						x						
		12,5	219,5							x					
244,5												x			
250	273	6,3	260,4	x	x										
		7,1	258,8			x	x								
		8,8	255,4					x							
		12,5	248						x						
> 250															Special Execution

DN	Schedule	D _z	t	D _w	ANSI (ASME B36.10M)											
					150	300	600	900	1500	2500						
1"	40	33,4	3,4	26,6	x	x	x	x								
	80		4,5	24,4						x						
	160		6,4	20,6									x			
	XXS		9,1	15,2										x		
1 1/2"	40	48,3	3,7	40,9	x	x	x	x								
	80		5,1	38,1	x	x	x	x								
	160		7,1	34,1									x			
	XXS		10,2	27,9										x		
2"	40	60,3	3,9	52,5	x	x	x	x								
	80		5,5	49,3									x			
	160		8,7	42,9										x		
	XXS		11,1	38,1											x	
3"	40	88,9	5,5	77,9	x	x	x									
	80		7,6	73,7									x			
	160		11,1	66,7										x		
	XXS		15,2	58,5											x	
4"	40	114,3	6	102,3	x	x	x									
	80		8,6	97,1										x		
	120		11,1	92,1											x	
	160		13,5	87,3												x
XXS	17,1	80,1													x	
6"	40	168,3	7,1	154,1	x	x										
	80		11	146,3												
	120		14,3	139,7												
	160		18,3	131,7												
8"	20	219,1	6,4	206,3	x	x										
	30		7	205,1												
	40		8,2	202,7												
	60		10,3	198,5												
80	12,7	193,7														
10"	20	273	6,4	260,2	x	x										
	30		7,8	257,4												
	40		9,3	254,4												
	60		12,7	247,6												
80	15,1	242,8														
> 12"															Special Execution	

D_z [mm] External pipe diameter
D_w [mm] Internal pipe diameter
t [mm] Pipe wall thickness

Execution with reduction stub

Table 12b Dimensions [mm] for welding ends form BW

DN	PN / ANSI	A max	B min	L	
25	PN10...CL300	38	20	50	
	PN63...CL600	48			
	PN160; CL900	40	23		
	PN250...CL2500	48			
40	PN10...CL300	64	42		
	PN63...CL600	75			
	PN160; CL900		38		
	PN250...CL2500	66	28		
50	PN10...CL600	80	55		
	PN160; CL900		50		
	PN250...CL2500	92	42		
	80	PN10...CL300	110	82	75
PN63...CL600		122			
PN160; CL900		111	76		
PN250...CL2500		127	56		
100	PN10...CL600	144	102		
	PN160; CL900				
	PN250...CL2500	165	81		
	150	PN10...CL300	183	160	
PN63...CL600		196			
PN160; CL900		217	154		
200		PN10...CL300	243	200	150
	PN63...CL600	248			
	PN10...CL300	291	248		
	PN63...CL600	346			

Table 12a contains series of basic welding connections. It is allowed to execute connections for other dimensions of pipes. Should pipe dimensions fall within the range \varnothing A max and \varnothing B min, connection can be executed as cast. Otherwise reduction stub is to be welded to body end, which shall result in extension for housing by L or 2L size.

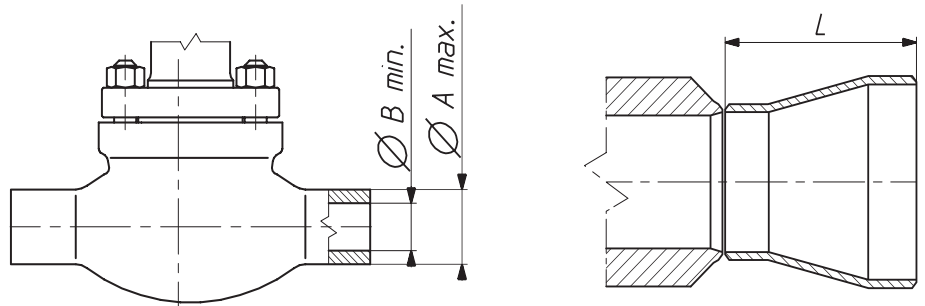

Fig. 3 External and Internal Diameters with Dimension for reduction stub

PNEUMATIC ACTUATOR TYPE P/R; P1/R1

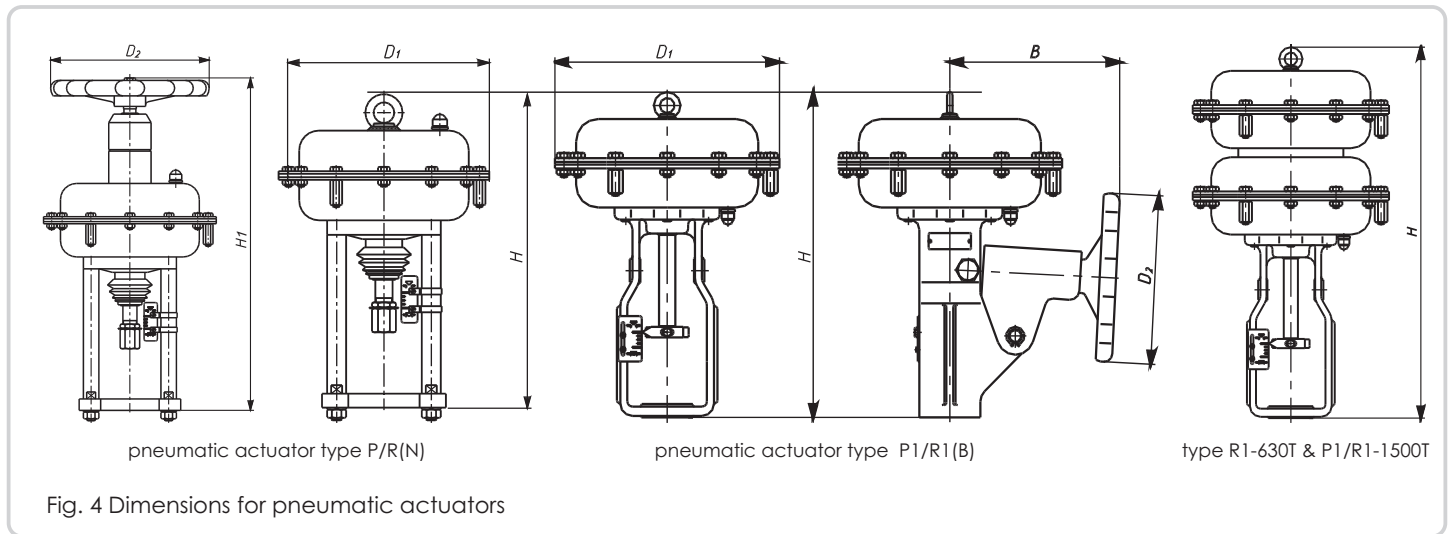

Table 13 Dimensions & Weight for pneumatic actuators

Type	Actuator Size [cm ²]	Diaphragm eff. area [cm ²]	Stroke [mm]	B	D1	D2	H	H1	Weight [kg] (P/R; P1/R1)	Revolutions per stroke (P/R-N; P1/R1-B)	Weight [kg] (P/R-N; P1/R1-B)
P/R	250	250	20	-	240	225	324	486	10	5	14,5
P/R	400	400		-	305		332	494	16		20,5
P1/R1	400	400		255	305		453	-	20		28
P/R	630	630	20; 38	-	375	305	424	586	30	5; 9	37
P1/R1				280			-	40	50		
R	630T	2 x 630		-	-		-	638	-		45
P/R	1000	1000	38; 50; 63	-	477	450	607	847	74	8; 10; 13	100
P1/R1				340			-	85	105		
P/R	1500	1500		38; 50; 63; 80; 100	-		550	450	704		-
P1/R1			410		-	120			150		
P/R	1500T	2 x 1500	-		-	-	1008		-	200	-
P1/R1			410	-	225	255					

MANUAL ACTUATOR TYPE 20

Table 14 Dimensions & Weight for manual actuator

Type	Stroke [mm]	d ₁	d ₂	H	D	Revolutions per stroke	Weight [kg]
20-20-57-M12	20	M12x1,25	57,15	265	228	8	7,5
20-20-84-M12			84,15				
20-38-57-M12	38	M16x1,5	57,15	385	298	15	10
20-38-57-M16			84,15				
20-38-84-M16			95,25				
20-50-57-M16	50	M16x1,5	57,15	385	457	16	16
20-50-84-M16			84,15				
20-50-95-M16			95,25				
20-63-84-M20	63	M20x1,5	84,15	533	610	20	24
20-63-95-M20			95,25				
20-80-84-M20	80	M20x1,5	84,15	533	610	19	24
20-80-95-M20			95,25				
20-100-95-M24	10	M24x1,5	95,25	533	610	19	24

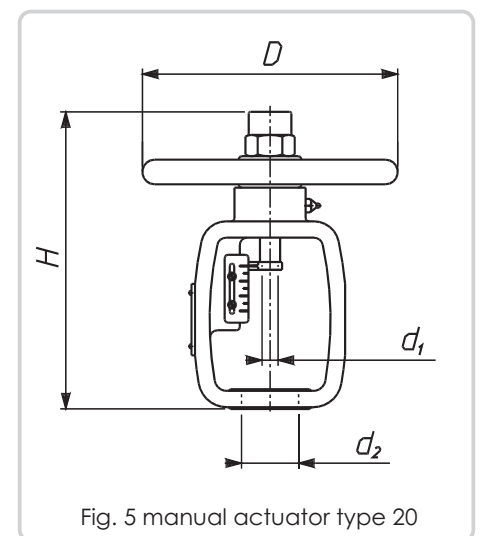

Fig. 5 manual actuator type 20