

## Application

The range of applications of the rotary plug valve BR33 corresponds to the "standard" control valve, but it can also be used for many special applications. This valve is specifically used to regulate the flow of media containing solids in automated industrial installations.

The rotary plug valve is especially useful for the control of flow under conditions with high probability of cavitation and erosion. The BR33 also has high rangeability (200:1), enabling larger control ranges.

With the KV's adjustment, integrated into the associated rotary actuator BR99, it is possible to achieve different opening angles of the rotary plug, leading to larger KV's without the need to exchange plug and seat.

## Features

- » Nominal Diameters from DN25 up to DN300
- » Nominal Pressure from PN10 up to CL300
- » Face-to-Face length as per DIN EN 60534-3-1, 60534-3-2 or ANSI/ISA 75.08
- » Temperature range -40°C up to +250°C (optional +450°C)
- » Leakage Class IV and VI according to DIN EN 60534-4
- » Characteristic: Linear (L); Equal-percentage (P) with positioner
- » Rangeability 200:1
- » Design with Flange ends or Wafer type (Sandwich), TA-Luft, Bearing seal (upgradeable) and Outlet sleeve (upgradeable)
- » Design as per Pressure Equipment Directive 2014/68/EU
- » Conformity CE and EAC
- » Optional certification/confirmation according to ATEX 2014/34/EU, GOST-R (TR), SIL2 (IEC 61508) and AD2000 Merkblatt



## Design and technical Specification

Diameters: DN25; 40; 50; 80; 100; 150; 200; 250; 300

Pressure: PN10; 16; 25; 40 as per DIN EN 1092-1:2013 and DIN EN 1092-2:1999  
ANSI CL150; 300 and DIN EN 1759-1:2005

Flanges as per DIN EN 1759-1:2005 can be assembled with flanges execution per standards ANSI / ASME B16.5 and MSS SP44. They correspond to the standard DIN EN 7005-1:2002 following pressure ranges: CL150 ≙ PN20 and CL300 ≙ PN50

Table 1 Flange Versions

Material	Nominal Pressure	Flange Facing Identification			
		Raised Face	Groove	Recess	Ring-Joint
Carbon Steel Stainless Steel	PN10; 16; 25; 40	B <sup>2)</sup>	D	F	-
	CL150		-	-	J (RTJ)
	CL300		DL (D1 <sup>1)</sup> )	F (F1)	

<sup>1)</sup> only for CL300; <sup>2)</sup> B1 – (Ra = 12,5 mm, concentric surface structure "C"), B2 – (Ra as agreed with the customer); (J) – as per ASME B16.5

Table 2 Packing and Bonnet Versions

Packing	PN / CL	Temperature [°C]	
		Standard	Extended Yoke
PTFE V-Ring	PN10...CL300	-46...+200	+200...+300
PTFE+Graphite			
PTFE V-Ring / TA-Luft		+200...+250	+200...+450
Graphite			
Graphite / TA-Luft			

Table 3 Application range for soft seated version

Version	Operating Temperature [°C]		Max. Operating Pressure [bar]
	Min.	Max.	
soft seat (PTFE inlay)	-46	+260	35

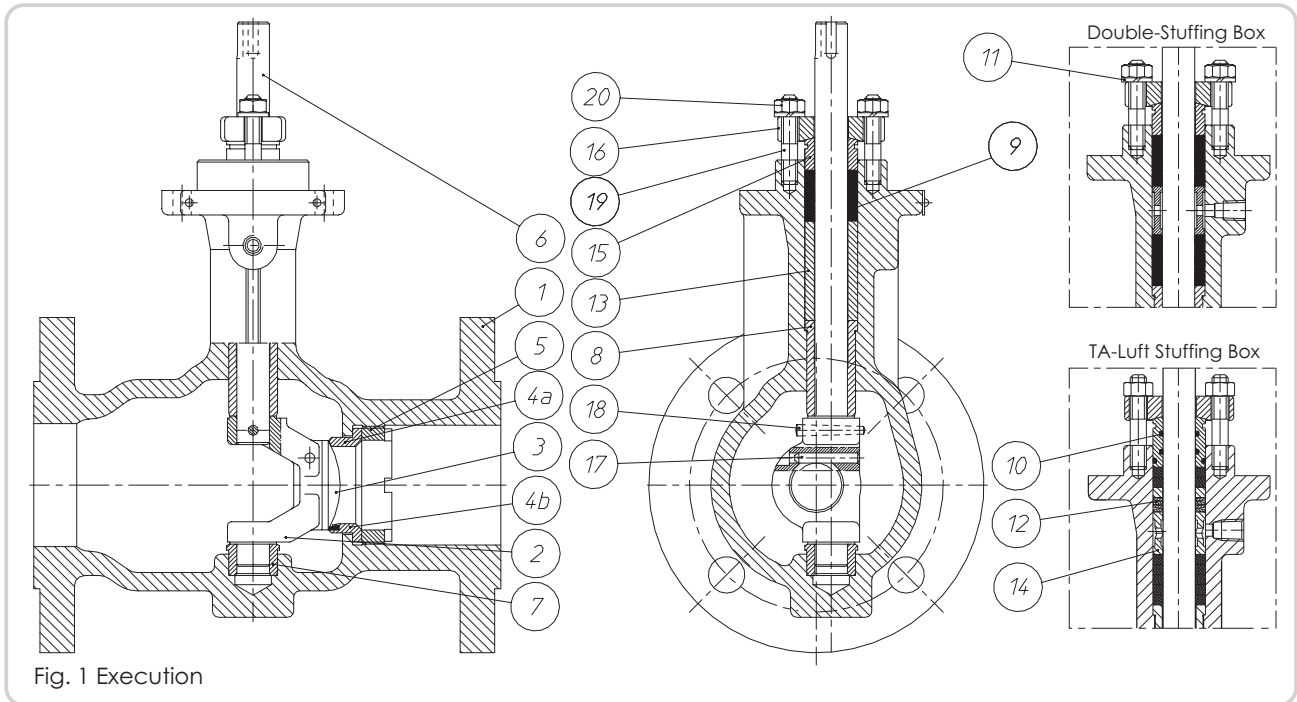

Fig. 1 Execution

Table 4 Components and Materials

No.	Component	Material				
1	Body	GP240GH (1.0619)	WCB	G20Mn5 (1.6220)	GX5CrNiMo19-11-2 (1.4408)	CF8M
2	Bridge					
3	Plug	X6CrNiMoTi17-12-2 (1.4571); X6CrNiMoTi17-12-2 (1.4571) + Stellite X2CrNiMoTi17-12-2 (1.4404); X2CrNiMoTi17-12-2 (1.4404) + Stellite				
4	Seat	X6CrNiMoTi17-12-2 (1.4571); X6CrNiMoTi17-12-2 (1.4571) + Stellite; X6CrNiMoTi17-12-2 (1.4571) + PTFE X2CrNiMoTi17-12-2 (1.4404); X2CrNiMoTi17-12-2 (1.4404) + Stellite; X2CrNiMoTi17-12-2 (1.4404) + PTFE				
5	Screwed Plug	X6CrNiMoTi17-12-2 (1.4571)				
6	Shaft					
7	Plug Guiding	X6CrNiMoTi17-12-2 (1.4571) + Stellite + Chrom(III)-nitride X6CrNiMoTi17-12-2 (1.4571) + PTFE				
8	Shaft Guiding					
9	Packing	PTFE+Graphite, PTFE-V, Graphite				
10	Sealing Ring	FKM				
11	Sweep Ring	VMQ				
12	Spring	12R10 (SANDVIK)				
13	Spacer Sleeve	X6CrNiMoTi17-12-2 (1.4571)				
14	Lubricating Sleeve					
15	Press Sleeve	X6CrNiMoTi17-12-2 (1.4571); X2CrNiMoTi17-12-2 (1.4404)				
16	Press Lever					
17	Cylindrical Pin	X6CrNiMoTi17-12-2 (1.4571)				
18	Plug Pin					
19	Stud Bolt	8.8			A4-70	
20	Nut	8			A4-70	
•	Rec. Spare Parts					

Material	Standard
GP240GH (1.0619)	DIN EN 10213-2
WCB	ASTM A 216
G20Mn5 (1.6220)	EIN EN 10213-3
GX5CrNiMo19-11-2 (1.4408)	DIN EN 10213-4
CF8M	ASTM A351
X6CrNiMoTi17-12-2 (1.4571)	DIN EN 10088
X2CrNiMoTi17-12-2 (1.4404)	DIN EN 10088

NOTE: » Padding of Surface with Stellite: ~ 40HRC

## Features

Due to the one-piece housing all occurring pipeline forces are compensated and have no effect on the torque and there are no additional forces on the seat and plug. Flow velocities minimized by the large volume and favorable aerodynamic housing (no deflection). The preferred flow direction (flow to close) has an added anti-wear property. The construction of the bridge construction ensures a free flow and a free of dead space. The double eccentricity of the bridge reduces the drive torque to a minimum, required for the safe closure of the valve. The plug of the BR33 control valve is a simple rotationally symmetrical part, always identical and therefore easily replaceable. By the double eccentric bearing and the required rotation angle of 60° for control, the BR33 has an almost linear inherent characteristic for maximum and reduced KVs.

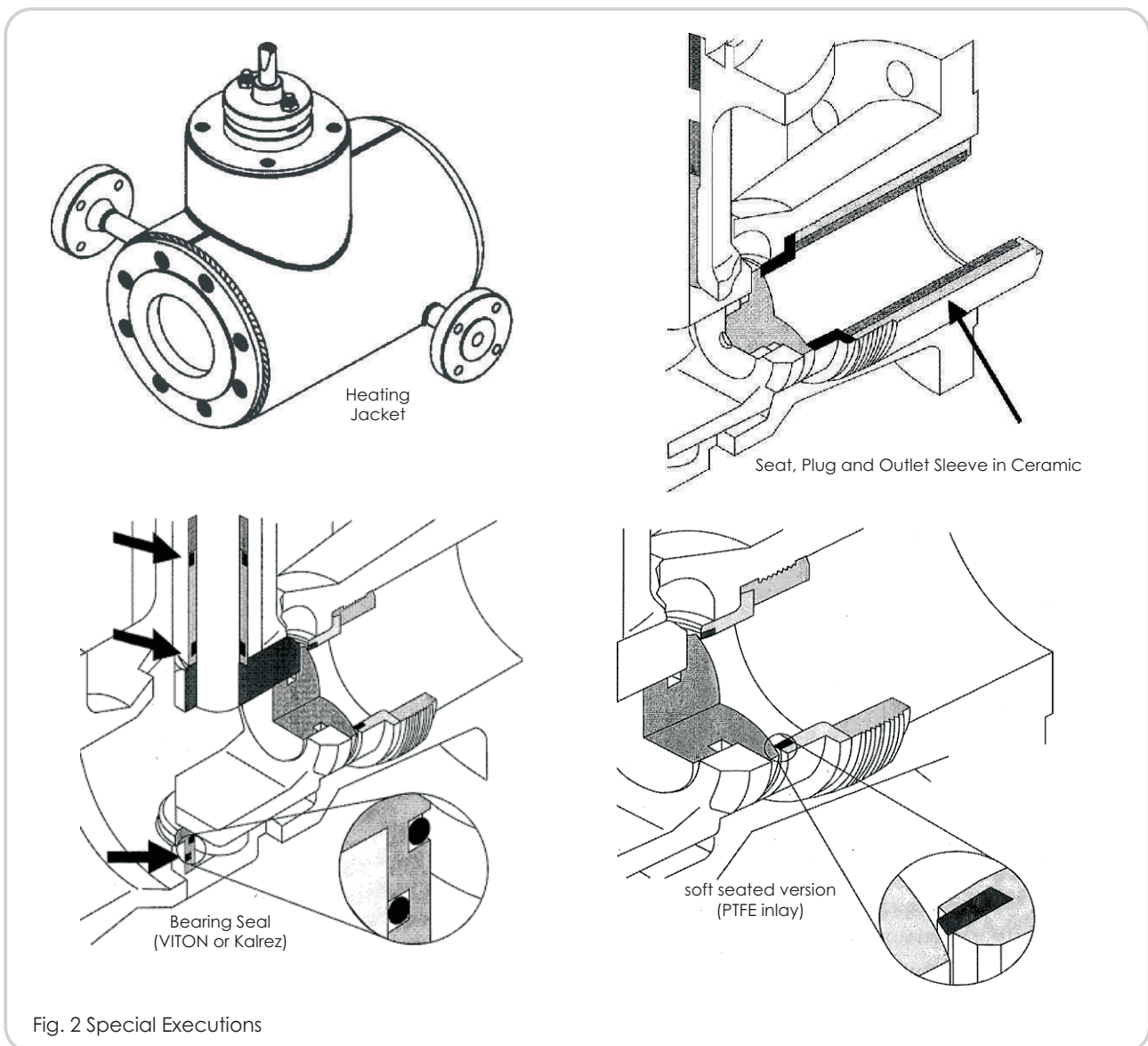

## Application ranges:

- » Heating Jacket with 2 or 3 Connections
- » Seat, Plug and Outlet Sleeve in 1.4571 + Stellite at Cavitation or Solids
- » Seat, Plug and Outlet Sleeve in Ceramic (Si3N4) at elevated Solids (e.g. calcium hydroxide)
- » Bearing Seal with O-Rings (VITON or Kalrez) at crystalizing, polymerized media

Table 4a...4e Allowable Operating Pressure

Table 4a		Material: <b>GP240GH (1.0619)</b> nach DIN EN 10213-2								
PN / CL	Standard	Temperature [°C]								
		-10...+50	100	150	200	250	300	350	400	450
		Max. Operating Pressure [bar]								
PN10	DIN EN 1092-1	10	9,2	8,8	8,3	7,6	6,9	6,4	5,9	-
PN16		16	14,8	14	13,3	12,1	11	10,2	9,5	-
CL150	DIN EN 1759-1	17,3	15,4	14,6	13,8	12,1	10,2	8,4	6,5	-
PN25	DIN EN 1092-1	25	23,2	22	20,8	19	17,2	16	14,8	-
PN40		40	37,1	35,2	33,3	30,4	27,6	25,7	23,8	-
CL300	DIN EN 1759-1	45,3	40,1	38,1	36	32,9	29,8	27,8	25,7	-

Table 4b		Material: <b>G20Mn5 (1.6220)</b> nach DIN EN 10213-3								
PN	Standard	Temperature [°C]								
		-40	100	150	200	250	300	350	400	450
		Max. Operating Pressure [bar]								
PN10		6	6	3,8	3,6	3,48	3,4	-	-	-
PN16		16	16	10,1	9,6	9,28	9,07	-	-	-
PN25		25	25	15,8	15	14,5	14,2	-	-	-
PN40		40	28	28	27	26	25	-	-	-

Table 4c		Material: <b>GX5CrNiMo19-11-2 (1.4408)</b> as per DIN EN 10213-4								
PN / CL	Standard	Temperature [°C]								
		-10...+50	100	150	200	250	300	350	400	450
		Max. Operating Pressure [bar]								
PN10	DIN EN 1092-1	10	10	9	8,4	7,9	7,4	7,1	6,8	6,7
PN16		16	16	14,5	13,4	12,7	11,8	11,4	10,9	10,7
CL150	DIN EN 1759-1	17,9	16,3	14,9	13,5	12,1	10,2	8,4	6,5	4,7
PN25	DIN EN 1092-1	25	25	22,7	21	19,8	18,5	17,8	17,1	16,8
PN40		40	40	36,3	33,7	31,8	29,7	28,5	27,4	26,9
CL300	DIN EN 1759-1	46,7	42,5	38,9	35,3	32,9	30,5	28,8	27,6	26,9

Table 4d		Material: <b>WCB</b> as per ASTM A216								
PN / CL	Standard	Temperature [°C]								
		-10...+50	100	150	200	250	300	350	400	450
		Max. Operating Pressure [bar]								
PN10	DIN EN 1092-1	10	10	9,7	9,4	9	8,3	7,9	6,7	-
PN16		16	16	15,6	15,1	14,4	13,4	12,8	10,8	-
CL150	DIN EN 1759-1	19,3	17,7	15,8	14	12,1	10,2	8,4	6,5	-
PN25	DIN EN 1092-1	25	25	24,4	23,7	22,5	20,9	20	16,9	-
PN40		40	40	39,1	37,9	36	33,5	31,9	27	-
CL300	DIN EN 1759-1	50	46,4	45,1	43,9	41,8	38,9	36,9	34,6	-

Table 4e		Material: <b>CF8M</b> as per ASTM A351								
PN / CL	Standard	Temperature [°C]								
		-10...+50	100	150	200	250	300	350	400	450
		Max. Operating Pressure [bar]								
PN10	DIN EN 1092-1	8,9	7,8	7,1	6,6	6,1	5,8	5,6	5,4	5,3
PN16		14,3	12,5	11,4	10,6	9,8	9,3	9	8,7	8,5
CL150	DIN EN 1759-1	18,4	16	14,8	13,6	12	10,2	8,4	6,5	4,6
PN25	DIN EN 1092-1	22,3	19,5	17,8	16,5	15,5	14,6	14,1	13,6	13,4
PN40		35,6	31,3	28,5	26,4	24,7	23,4	22,6	21,8	21,4
CL300	DIN EN 1759-1	48,1	42,3	38,6	35,8	33,5	31,6	30,4	29,3	29

**NOTE:** At operating temperatures below -10°C\* a notch impact test must be performed according to **AD2000 Merkblatt W10\*\***, in which the lowest temperatures are mentioned in three categories (I, II, III) for the respective usage cases.

\* For low temperature usage a technical review of the manufacturer is required!

\*\* The temperature limits mentioned in AD2000 Merkblatt W10 are purely theoretical values and relate only to the indicated material. Due to the multiplicity of used components - of a control valve - it also requires a separate review of the manufacturer!

Table 5 Flow Ratios [KV<sub>s</sub>]

NC, Spring close													
DN	C	K	KV <sub>s</sub> [m <sup>3</sup> /h]				Ø Seat D [mm]	R99-120		R99-240		R99-780	
			100% [60°]	75% [45°]	45% [25°]	120% [90°]		Spring Range [bar]					
								1,0...2,0	1,6...3,2	0,8...1,6	1,6...3,2	1,0...2,0	1,6...3,2
25	1,03	1,23	15	11	7	18	18	50	-	-	-	-	-
	0,45	0,82	6	5	3	7	12	50	-	-	-	-	-
	0,38	0,75	3	2	1	4	10	50	-	-	-	-	-
40	4,6	2,9	40	30	18	48	28,5	50	-	-	-	-	-
	2,2	2,3	16	12	7	19	20	50	-	-	-	-	-
50	8,2	4,4	60	45	27	72	38	50	-	-	-	-	-
	3,9	2,9	24	18	11	29	26	50	-	-	-	-	-
80	26,9	9,2	150	113	68	180	58	-	32	50	50	-	-
	11,5	6,1	60	45	27	72	38	-	50	50	50	-	-
100	52,9	14,3	240	180	108	288	72	-	13	27	50	-	-
	23,5	10,4	96	72	43	115	48	-	36	50	50	-	-
150	169	32	500	375	225	600	110	-	-	9	23	50	50
	72	19,6	200	150	90	240	72	-	-	25	50	50	50
200	312	47,3	800	600	360	960	136	-	-	-	13	44	50
	131	30,1	320	240	144	384	88	-	-	-	37	50	50
250	635	74,8	1250	938	563	1500	170	-	-	-	5	20	45
	253	48	500	375	225	600	110	-	-	-	17	50	50
300	980	100	1800	1350	810	2160	200	-	-	-	2	12	28
	390	62	720	540	324	864	126	-	-	-	10	34	50

NO, Spring open													
DN	C	K	KV <sub>s</sub> [m <sup>3</sup> /h]				Ø Seat D [mm]	P99-120		P99-240		P99-780	
			100% [60°]	75% [45°]	45% [25°]	120% [90°]		Supply Pressure [bar] (Spring Range: 0,8...1,6 bar)					
								2,4	4,0	2,4	4,0	2,4	4,0
25	1,03	1,23	15	11	7	18	18	50	50	-	-	-	-
	0,45	0,82	6	5	3	7	12	50	50	-	-	-	-
	0,38	0,75	3	2	1	4	10	50	50	-	-	-	-
40	4,6	2,9	40	30	18	48	28,5	50	50	-	-	-	-
	2,2	2,3	16	12	7	19	20	50	50	-	-	-	-
50	8,2	4,4	60	45	27	72	38	50	50	-	-	-	-
	3,9	2,9	24	18	11	29	26	50	50	-	-	-	-
80	26,9	9,2	150	113	68	180	58	11	50	50	50	-	-
	11,5	6,1	60	45	27	72	38	33	50	50	50	-	-
100	52,9	14,3	240	180	108	288	72	2	24	27	50	-	-
	23,5	10,4	96	72	43	115	48	11	50	50	38	-	-
150	169	32	500	375	225	600	110	-	-	9	38	50	50
	72	19,6	200	150	90	240	72	-	-	24	50	50	50
200	312	47,3	800	600	360	960	136	-	-	-	23	44	50
	131	30,1	320	240	144	384	88	-	-	-	50	50	50
250	635	74,8	1250	938	563	1500	170	-	-	-	10	20	50
	253	48	500	375	225	600	110	-	-	-	29	50	50
300	980	100	1800	1350	810	2160	200	-	-	-	5	12	44
	390	62	720	540	324	864	126	-	-	-	17	34	50

Coefficients: FL=0,854; XT=0,6; FD=0,7; xFz=0,58

**NOTE:**

The indicated pressure drops (incl. K factor) refer to the version with **metallic sealing system** and should not exceed 70% of the allowable operating pressure for given nominal pressure, material execution and operating temperature as per Table 4. Theoretical acceptable pressure drops are included. Actual pressure drops with consideration of tolerance of spring manufacture and friction of internal parts of the actuator are lower than those given by 20%. With soft sealing system (**leakage class VI**) and diameter > DN200, an extra safety of 10% is needed.

 Calculation of needed torque with **Leakage Class IV**: 
$$\frac{\Delta p * C + 10 * K}{7,5} = Nm$$

 and needed torque for **Leakage Class VI**: 
$$\frac{\Delta p * C + 10 * (K * 1,65)}{7,5} = Nm$$



# Rotary Control Valve BR33

## The Flexibility:

Adjustment of rotation angle of actuator type BR99 via system of two levers. Lever attached to diaphragm plate always turns by 30°, hence stroke, pressure range and positioner feedback lever position do not change. With change in setting of bearing pin turn angle of crankshaft and also valve shaft changes too, within values 25°, 45°, 60° and 90°. In closed position of valve movement of bearing pin to crankshaft guide at the beginning of lever rotation is parallel, hence closed position of valve is maintained.

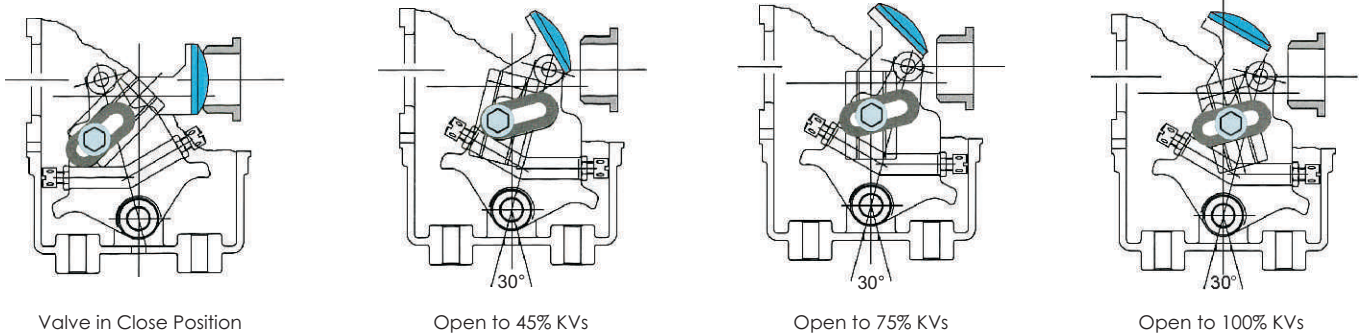

Connector, which connects actuator to valve shaft, allows turning of actuator to valve by each 90° and since it is accessible from outside it eliminates the need for actuator or valve disassembly.

function **NC**, Spring close

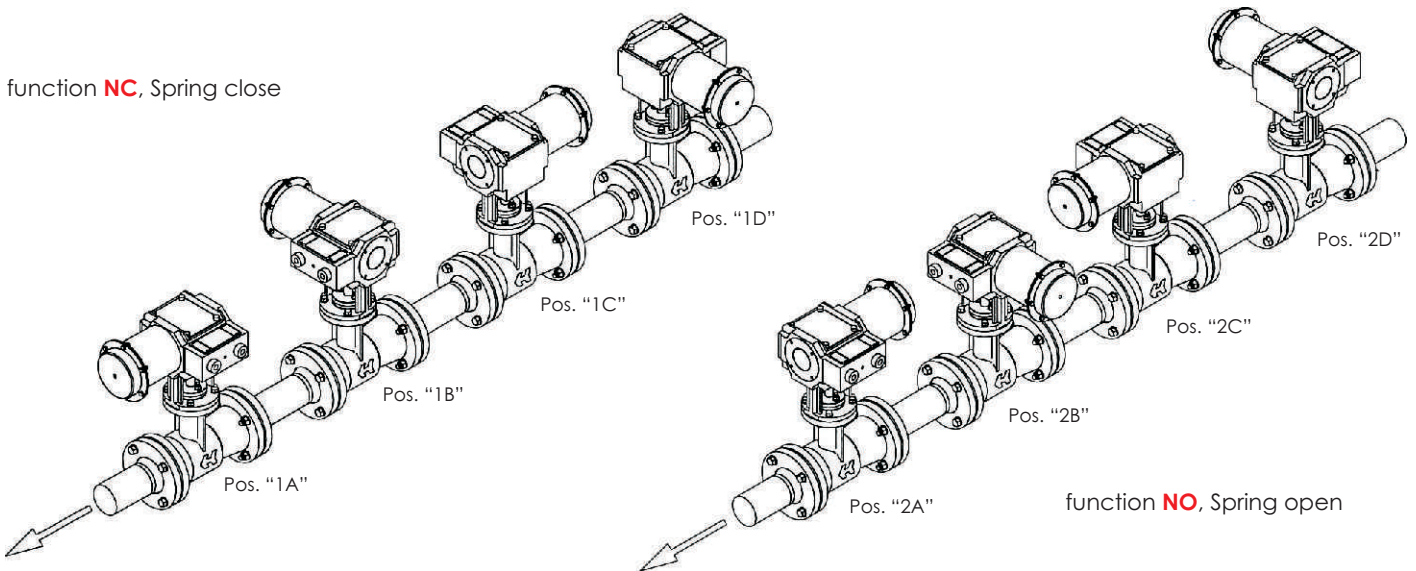

Pneumatic Actuator Type P/R99 (optional with Manual Override Type N)

Table 6 Pneumatic Actuator

Size	Diaphragm eff. area [cm <sup>2</sup> ]	max. allowable Supply Pressure [bar]	Spring Range [bar]	Connection [ISO 5211]	L	K	G	F	S	Weight [kg]
P/R99-120	120	6.0	1.0...2.0; 1.6...3.2	F07	110	36	55	16	24	18
P/R99-240	240			F12			180			
			F14	100	28	60		54		
				F16					130	
P/R99-780	780		1.0...2.0; 1.6...3.2	F14	200	60	100	36	71	189
							F16			

Pneumatic Connection: G 1/4", Pipe Diameter: Ø 6x1; Ø 8x1; Ø 10x1; Ø 12x1; Ambient Temperature Range: -30...+80°C; Maximum Supply Pressure: 6 bar

Components

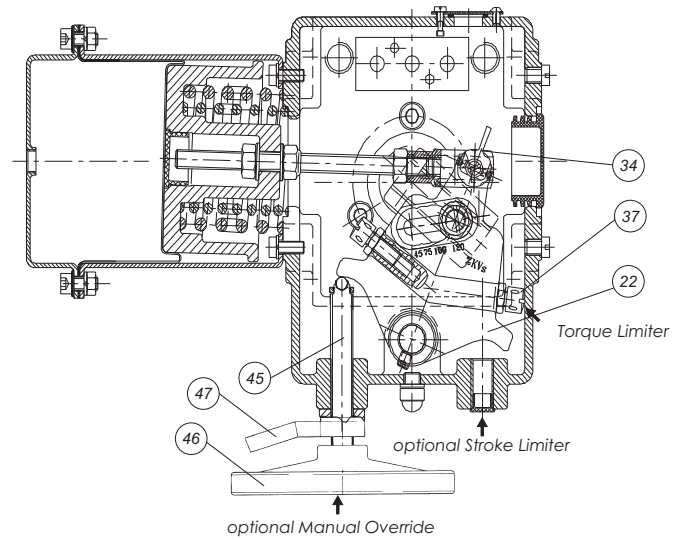
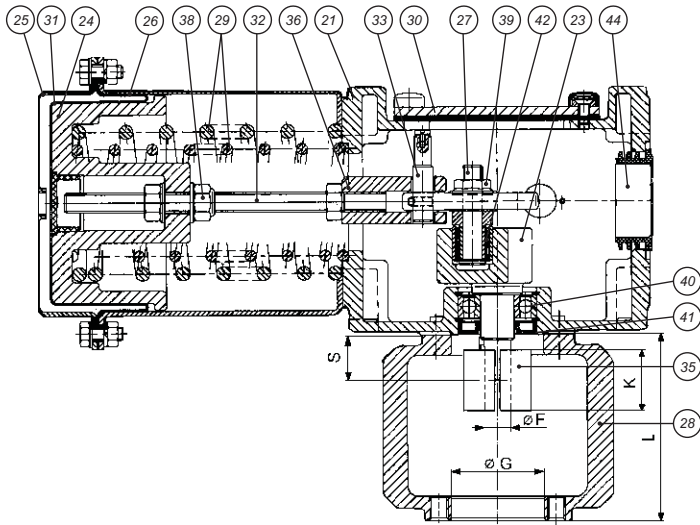

21	Actuator Housing	28	Actuator Yoke	35	Connector	42	Needle Bearing
22	Actuator Lever	29	Spring (1 + 2)	36	Fork	44	Closure Plug
23	Crankshaft	30	Front Nameplate	37	Torque Limiter	45	Handwheel Lock
24	Diaphragm Plate	31	Diaphragm	38	Adjusting Nut	46	Handwheel
25	Diaphragm Housing	32	Push Rod	39	Securing Nut	47	Locking Lever
26	Spring Case	33	Cylindrical Pin	40	Ball Bearing at Crankshaft	•	Rec. Spare Parts
27	Bearing Pin	34	Stroke Indicator	41	Sealing Ring at Crankshaft		

Table 7 Connection Dimensions

Dimensions according to ISO 5211				
DN	ISO 5211	E	F	G
25...50	F07	83	16	55
80...100	F12			
150	F14	116	28	100
		113		
200...300	F16	123	36	130
		133		
		120		

Dimensions incl. yoke and connector						
Flange	D <sub>1</sub>	D <sub>2</sub>	d	L	L <sub>1</sub>	K
F05	35	50	7	100	15	14
F07	55	70	9		18	17
F12	85	125	13	140	22	27
F14	100	140	17		37	36
F16	130	165	22	48	46	

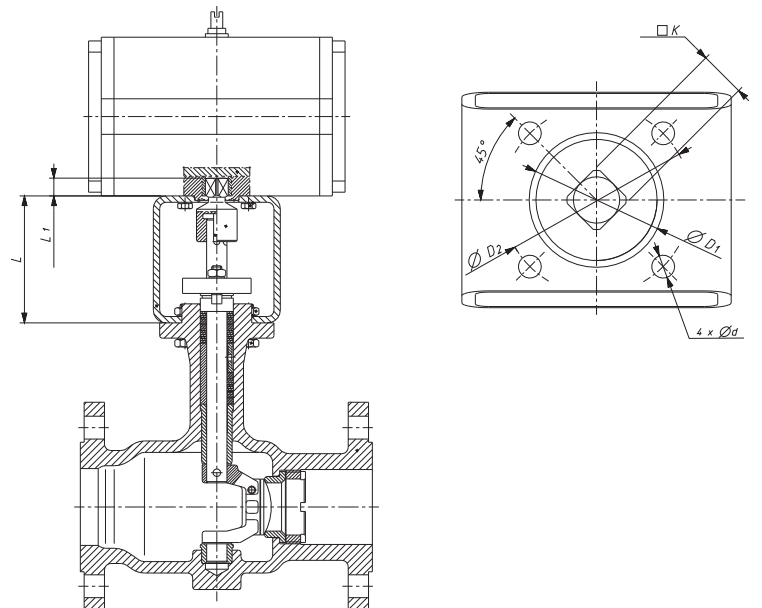
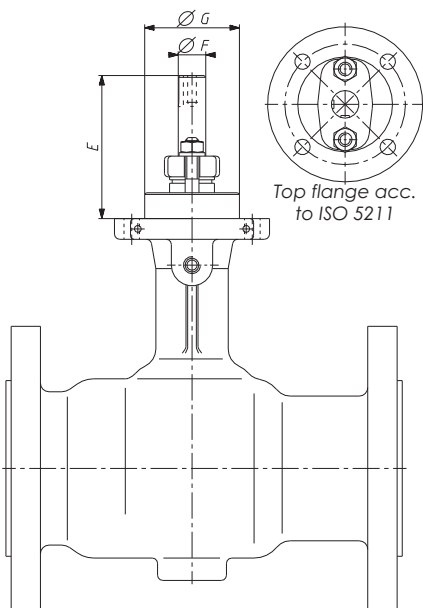

# Rotary Control Valve

## BR33

Table 8 Dimensions [mm] & Weight [kg]

DN	PN/ANSI	Actuator	H	h	Ø d	Ø A	C	L	LM	B	R	Q	V	T	Weight <sup>1)</sup> [kg]
25	PN40	99-120	409	134	37	175	55	160	89	374	92	105	90	234	26
	CL150							184	113						26
	CL300							197	126						27
	Sandwich (KDF)							102	60						24
40	PN40	99-120	415	140	48	175	64	200	115	374	92	105	90	234	29
	CL150							222	137						29
	CL300							235	150						30
	Sandwich (KDF)							114	64						25
50	PN40	99-120	420	145	60	175	70	230	123	374	92	105	90	234	31
	CL150							254	135						31
	CL300							267	141						33
	Sandwich (KDF)							124	70						26
80	PN40	99-120	467	192	88	175	90	310	190	573	135	143	75	348	45
	CL150							298	178						45
	CL300							318	197						50
	Sandwich (KDF)							165	92						35
	PN40	99-240	607	192	88	250	90	310	190	573	135	143	75	348	81
	CL150							298	178						81
	CL300							318	197						86
	Sandwich (KDF)							165	92						71
100	PN40	99-120	477	202	107	175	103	350	215	374	92	105	90	234	58
	CL150							352	223						58
	CL300							368	234						68
	Sandwich (KDF)							194	116						43
	PN40	99-240	617	202	107	250	103	350	270	573	135	143	75	348	94
	CL150							352	241						94
	CL300							368	263						104
	Sandwich (KDF)							194	140						79
150	PN40	99-240	699	284	162	250	195	480	270	573	135	143	75	348	132
	CL150							451	241						123
	CL300							473	263						144
	Sandwich (KDF)							229	140						99
	PN40	99-780	789	284	162	430	195	480	365	925	220	230	90	526	267
	CL150							451	336,5						258
	CL300							473	349						279
	Sandwich (KDF)							229	157						234
200	PN40	99-240	727	312	204	250	216	600	365	573	135	143	75	348	192
	CL150							543	336,5						182
	CL300							568	349						212
	Sandwich (KDF)							243	157						132
	PN40	99-780	817	312	204	430	216	600	365	925	220	230	90	526	327
	CL150							543	336,5						317
	CL300							568	349						347
	Sandwich (KDF)							243	157						267
250	PN40	99-240	751	336	250	250	250	730	430	573	135	143	75	348	327
	CL150							673	401,5						297
	CL300							708	421						337
	Sandwich (KDF)							297	190						227
	PN40	99-780	841	336	250	430	250	730	430	925	220	230	90	526	462
	CL150							673	401,5						432
	CL300							708	421						472
	Sandwich (KDF)							297	190						362
300 */**	PN40	99-240	769	338	300	250	258	850	553	573	135	143	75	348	575
	Sandwich (KDF)							338	197,5						337
	PN40	99-780	859	342	300	430	258	850	553	925	220	230	90	526	710
	Sandwich (KDF)							338	197,5						472

<sup>1)</sup> CL300: L=865 (+/-1mm); flange thickness=508 (+/-1mm); Ø flange = 521mm \*\*) CL150: Body PN40, boring acc. to CL150<sup>1)</sup> approx. weights incl. actuator

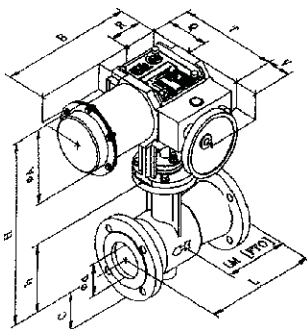

Flange Version with Actuator Type P/R99-120

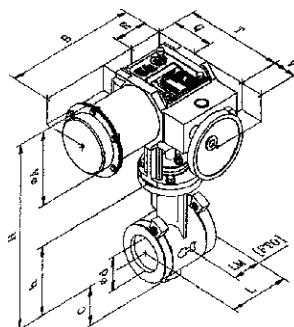

Sandwich Version with Actuator Type P/R99-120

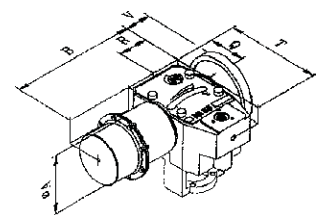

Actuator Type P/R99-240; P/R99-780